

ST. CLAIR COUNTY HOUSING AUTHORITY STREET AND PARKING IMPROVEMENTS ST. CLAIR COUNTY, ILLINOIS

HR
Hurst-Rosche, Inc.
PROFESSIONAL DESIGN NUMBER: 184-000298
NO. 5 BANK SQUARE
EAST ST. LOUIS, IL
PH: 618.398.0890
www.hurst-rosche.com
HILLSBORO, IL
SPRINGFIELD, IL
MARION, IL
NASHVILLE, TN
ARNOLD, MO

CIVIL ENGINEER:



Hurst-Rosche, Inc.
PROFESSIONAL DESIGN NUMBER: 184-000298
5 Bank Square
E. St. Louis, IL
PH: 618.398.0890
www.hurst-rosche.com
HILLSBORO, IL
MARION, IL
ARNOLD, MO
NASHVILLE, TN

INDEX OF SHEETS:

G-001	COVER SHEET
G-101	GENERAL NOTES
C-101	SITE PLAN AMP 1: IL30-09, BROOKLYN
C-102	SITE PLAN AMP 3: IL30-09, CAHOKIA HEIGHTS
C-103	SITE PLAN AMP 2: IL30-10, CAHOKIA HEIGHTS
C-104	SITE PLAN AMP 4: IL30-27, BELLEVILLE
C-105	SITE PLAN AMP 6: IL30-22, MILLSTADT
C-106	SITE PLAN AMP 6: IL30-19, IL 30-28, LENZBURG
C-501	MISCELLANEOUS DETAILS

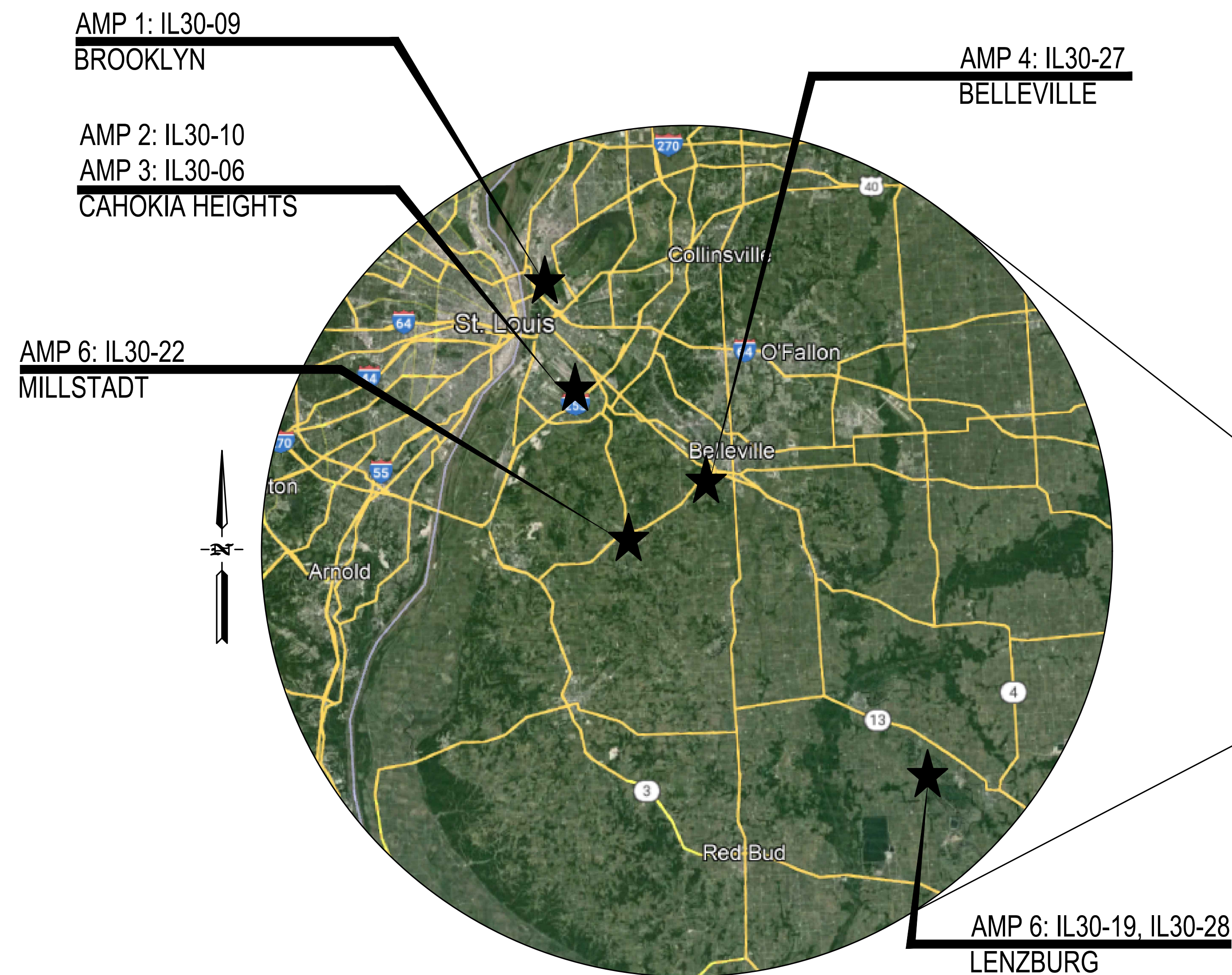

AREA LOCATION MAP
NOT TO SCALE

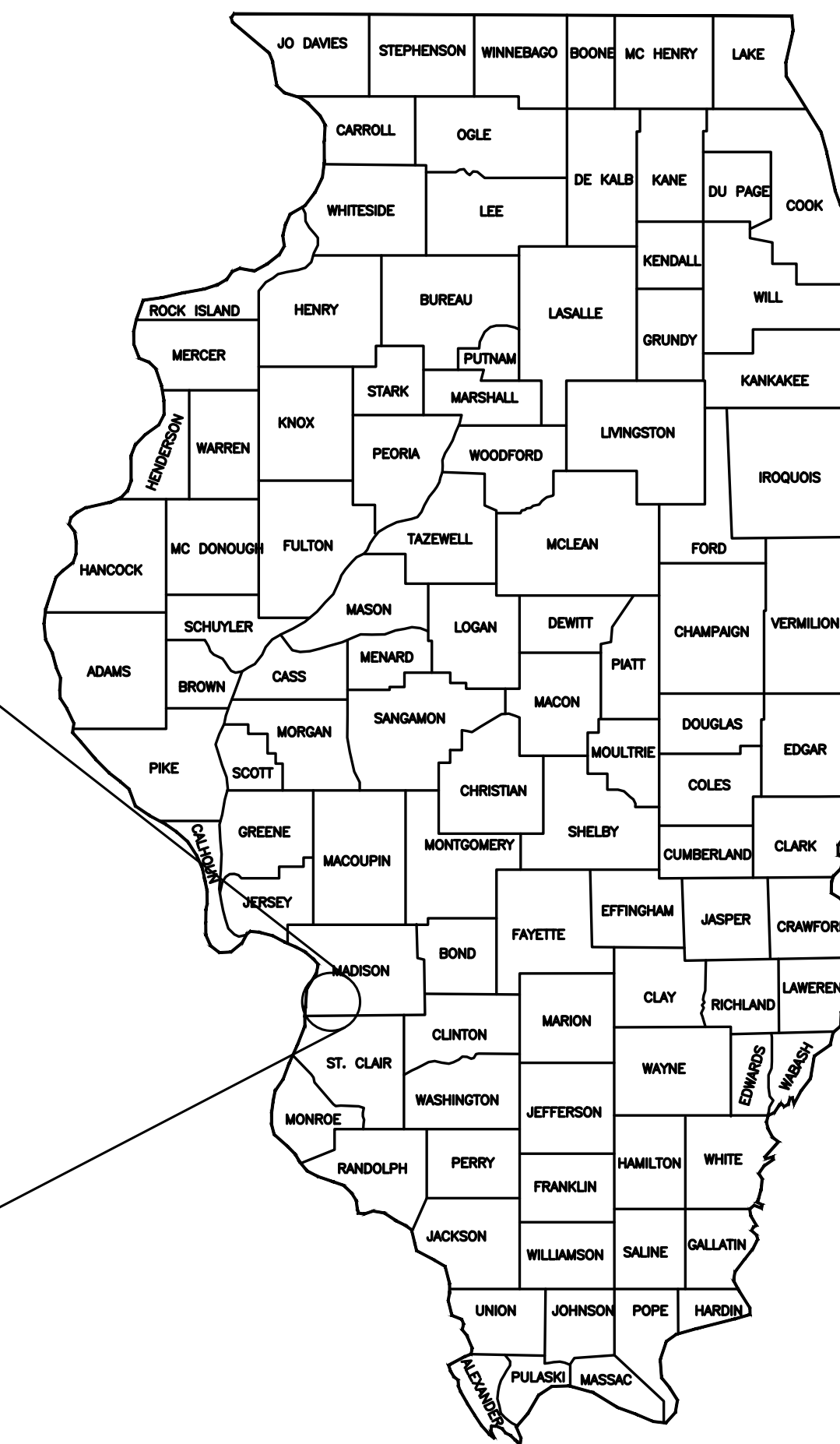

SIGNATURE
xx-xx-2022
DATE 11-30-2023
LICENSE EXPIRES

SCCHA STREET AND PARKING IMPROVEMENTS
BROOKLYN, CAHOKIA HEIGHTS, LENZBURG,
BELLEVILLE AND MILLSTADT
ST. CLAIR COUNTY, ILLINOIS 62204

MK.	DATE	DESCRIPTION

DATE: APRIL 29, 2024
PROJECT NO: 280-0474
DESIGN: SMS DRAWN: JMA CHECK: JLV

TITLE SHEET

G-001



Hurst-Rosche, Inc.
PROFESSIONAL DESIGN NUMBER: 184-000298

NO. 5 BANK SQUARE
EAST ST. LOUIS, IL
PH: 618.398.0890

www.hurst-rosche.com

HILLSBORO, IL
SPRINGFIELD, IL
MARION, IL
NASHVILLE, TN
ARNOLD, MO

SIGNATURE
xx-xx-2022
DATE
11-30-2023
LICENSE EXPIRES

SCCHA STREET AND PARKING IMPROVEMENTS
BROOKLYN, CAHOKIA HEIGHTS, LENZBURG,
BELLEVILLE AND MILLSTADT
ST. CLAIR COUNTY, ILLINOIS 62204

MK.	DATE	DESCRIPTION

DATE: APRIL 29, 2024
PROJECT NO: 280-0474
DESIGN: SMS DRAWN: JMA CHECK: JLW

GENERAL NOTES

G-101

GENERAL NOTES:

- CONTRACTOR SHALL REMOVE EXISTING CONSTRUCTION TO THE EXTENT SHOWN ON THE PLANS AND LEGALLY DISPOSE OF OFF-SITE. CONTRACTOR SHALL ALSO REMOVE AND DISPOSE OF ALL VEGETATION AFFECTING CONSTRUCTION WHEN THE CONSTRUCTION LIMITS SHOWN ON THE PLANS AND ALL SURPLUS UNSTABLE AND/OR UNSTABLE MATERIALS RESULTING FROM CONSTRUCTION OF THE PROJECT. THE CONTRACTOR SHALL TAKE NOTE OF EXISTING SITE CONDITIONS AND BE PREPARED TO MOVE OR DISPOSE OF OBJECTS OR MATERIALS WITHIN THE LIMITS OF THE PROJECT. SUCH WORK SHALL NOT BE CAUSE FOR ADDITIONAL COMPENSATION FOR A CHANGE IN THE SCOPE.
- CONTRACTOR SHALL TAKE ALL PRECAUTIONS NECESSARY TO AVOID DAMAGE TO EXISTING CONSTRUCTION AND UTILITIES TO REMAIN AND SHALL REPAIR DAMAGE CAUSED BY CONSTRUCTION/DEMOLITION AT NO ADDITIONAL COST TO THE OWNER. IT IS THE CONTRACTOR'S RESPONSIBILITY TO LOCATE, PROTECT AND SUPPORT ALL EXISTING UTILITIES DURING DEMOLITION OR WHEN CROSSINGS OCCUR. ANY DAMAGE TO THE UTILITIES SHALL BE THE SOLE RESPONSIBILITY OF THE CONTRACTOR. CONTRACTOR TO NOTIFY JULIE A MINIMUM OF 48 HOURS PRIOR TO ANY EXCAVATION. (800) 802-0123.
- CONTRACTOR SHALL COORDINATE ALL WORK WITH SCCHA AND RESIDENTS. CONTRACTOR MUST NOTIFY RESIDENTS A MINIMUM OF 48 HOURS PRIOR TO CONDUCTING WORK.
- AFTER ALL WORK IS COMPLETED, CONTRACTOR SHALL CLEAN WORK AREAS SO THAT THEY ARE FREE OF ANY CONSTRUCTION DIRT AND DEBRIS.
- NEW WORK SHALL MATCH EXISTING ADJOINING CONSTRUCTION FOR A SMOOTH TRANSITION UNLESS OTHERWISE NOTED.
- ALL WORK SHALL BE CONSTRUCTED IN ACCORDANCE WITH THE PLANS, I.D.O.T. STANDARD SPECIFICATIONS FOR ROAD AND BRIDGE CONSTRUCTION, LATEST EDITION, AND SPECIAL PROVISIONS.
- ALL SAW CUTTING OF EXISTING PAVEMENT SHALL BE CONSIDERED INCIDENTAL TO THE CONTRACT. THE MINIMUM SAW CUT DEPTH IN THE PAVEMENT SHALL BE 6" UNLESS OTHERWISE SPECIFIED IN THE PLANS.
- THE CONTRACTOR SHALL COORDINATE WITH THE PHA REGARDING CONTRACTOR PARKING AND CONSTRUCTION STAGING.
- PERMITS AND LICENSES OF A TEMPORARY NATURE NECESSARY FOR THE PROCESSION OF WORK SHALL BE SECURED AND PAID FOR BY THE CONTRACTOR.
- THE ARCHITECT/ENGINEER WILL PERFORM COMPACTION AND CONCRETE TESTING IN ACCORDANCE WITH THE SPECIFICATIONS.
- THE CONTRACTOR IS RESPONSIBLE FOR CONSTRUCTION LAYOUT AND STAKING.
- ALL TEMPORARY AGGREGATE SHALL BE REMOVED, GRADED, SEEDED AND MULCHED AS NECESSARY AT THE COMPLETION OF THE CONTRACT.
- ALL DISTURBED LAWN AREAS SHALL BE SEEDED AND MULCHED AS DIRECTED BY THE ARCHITECT/ENGINEER.
- THE CONTRACTOR IS RESPONSIBLE FOR PREVENTING EROSION OF THE SOIL EXPOSED BY DISTURBANCE DUE TO HIS OPERATIONS. THE CONTRACTOR SHALL CONSTRUCT TEMPORARY EROSION CONTROL IN ACCORDANCE WITH SECTION 280 OF THE IDOT STANDARD SPECIFICATIONS. NO ADDITIONAL COMPENSATION IS ALLOWED FOR TEMPORARY EROSION CONTROL.
- DIMENSIONS AND QUANTITIES NOTED ON DRAWINGS ARE APPROXIMATE AND ARE FOR GENERAL INFORMATION ONLY THE CONTRACTOR SHALL VERIFY ALL EXISTING AND NEW DIMENSIONS WITH FIELD CONDITIONS PRIOR TO BIDDING, FABRICATION AND CONSTRUCTION AND MAKE MINOR ADJUSTMENTS AS NECESSARY. NOTIFY THE ARCHITECT/ENGINEER OF ANY CONDITIONS THAT MAY AFFECT THE OUTCOME OF THE WORK.
- MAINTAINING DRAINAGE – IT SHALL BE THE RESPONSIBILITY OF THE CONTRACTOR TO MAINTAIN DRAINAGE FLOWS AT ALL TIMES DURING THE PERFORMANCE OF THE WORK. DAMAGE RESULTING FROM IMPROPER MAINTENANCE OF DRAINAGE SHALL BE IMMEDIATELY REPAIRED BY THE CONTRACTOR AT NO ADDITIONAL COST TO THE PHA. COST OF MAINTAINING FLOWS IS INCIDENTAL TO THE CONTRACT.
- EXCAVATION AND BACKFILL:
 - CONTRACTOR SHALL REMOVE AND DISPOSE OF ALL VEGETATION AFFECTING CONSTRUCTION WITHIN THE CONSTRUCTION LIMITS SHOWN ON THE PLANS IN ACCORDANCE WITH THE SPECIFICATIONS UNLESS OTHERWISE NOTED IN THE PLANS. ALL REMOVED VEGETATION SHALL BE DISPOSED OF WITHIN 7 DAYS OF REMOVAL.
 - AREAS TO RECEIVE FILL SHALL BE SCARIFIED TO A DEPTH OF 6 INCHES AND COMPACTED TO A MINIMUM 95% COMPACTION FOR ALL LIFTS BASED ON THE MAXIMUM DRY DENSITY IN ACCORDANCE WITH THE SPECIFICATIONS.
 - PLACE AND COMPACT FILL IN LIFTS NOT TO EXCEED 8" WHEN IN LOOSE CONDITION. FILL SHALL BE COMPACTED IN ACCORDANCE WITH THE SPECIFICATIONS.
 - SEE PAVEMENT SECTION DETAIL AS APPLICABLE FOR DRIVEWAY, SIDEWALKS AND PARKING AREAS.
 - THE REMOVAL OF UNSTABLE AND UNUSABLE MATERIAL IN ALL CUT AND FILL AREAS AND THEIR REPLACEMENT WITH SATISFACTORY MATERIAL, WHERE REQUIRED, SHALL BE INCLUDED IN THE COST OF THE CONTRACT.
 - THE CONTRACTOR SHALL GRADE AND PREPARE ALL SUBGRADES TO WITHIN 0.1 FEET OF PLAN GRADE.
 - ALL TOPSOIL, VEGETATION, ROOTS, AND ANY SOFT SOILS SHALL BE STRIPPED FROM PROPOSED SIDEWALK AND PAVEMENT AREAS. SITE SHALL THEN BE PROOF-ROLLED SCARIFIED, AND PROCESSED TO THE OPTIMUM MOISTURE CONTENT TO ATTAIN REQUIRED COMPACTION DENSITY OF SUB-GRADE SOILS.
- PARKING LOTS SHALL BE RESEALED USING AN ASPHALTIC EMULSION SLURRY SEAL PER SECTION 404 OF THE IDOT STANDARDS SPECIFICATIONS.
- PARKING BLOCKS SHALL BE CONCRETE FILLED POLYMER. THEY SHALL BE TUF-STUF PARKING BUMPERS BY TUF-TITE OR AN APPROVED EQUIVALENT.

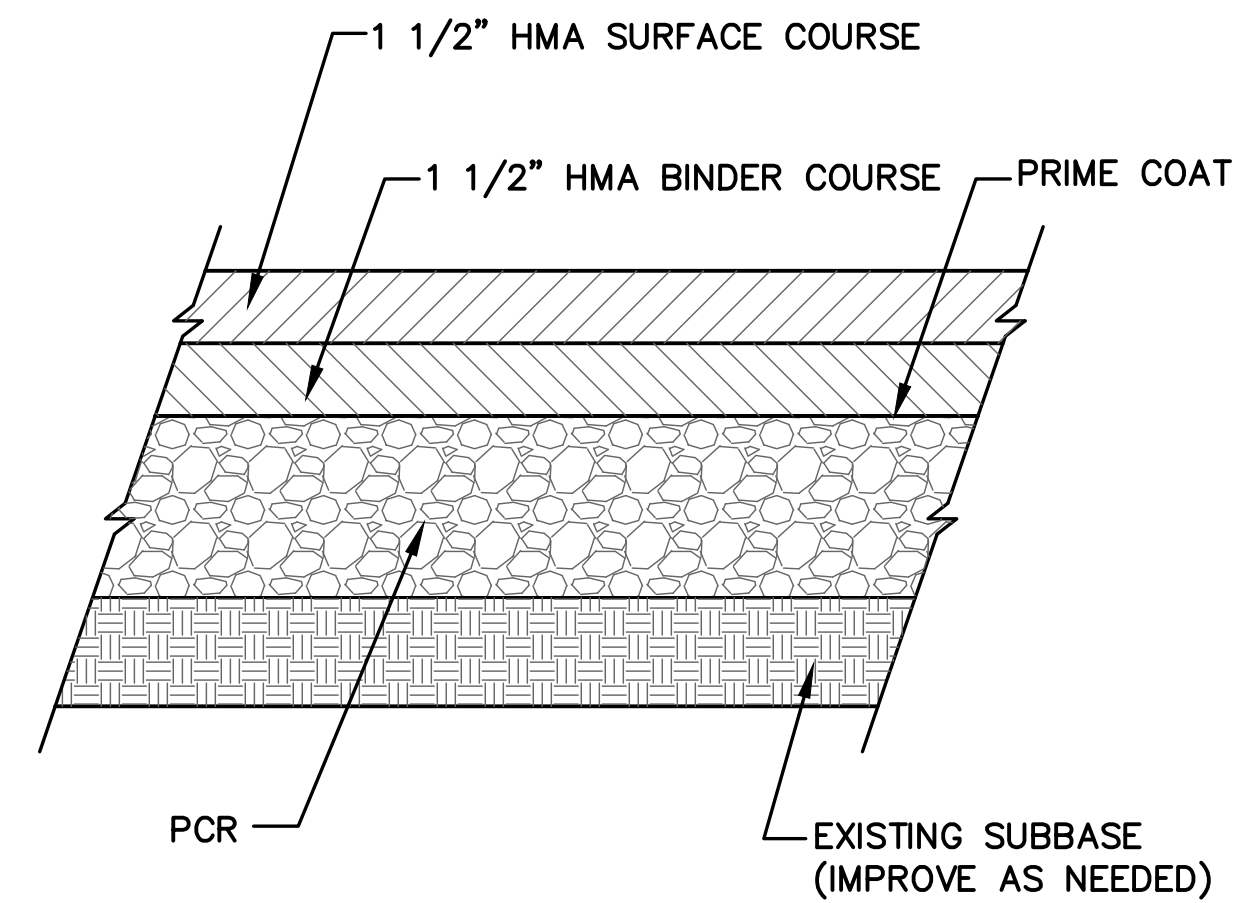

TYPICAL PAVEMENT REHABILITATION SECTION
NOT TO SCALE

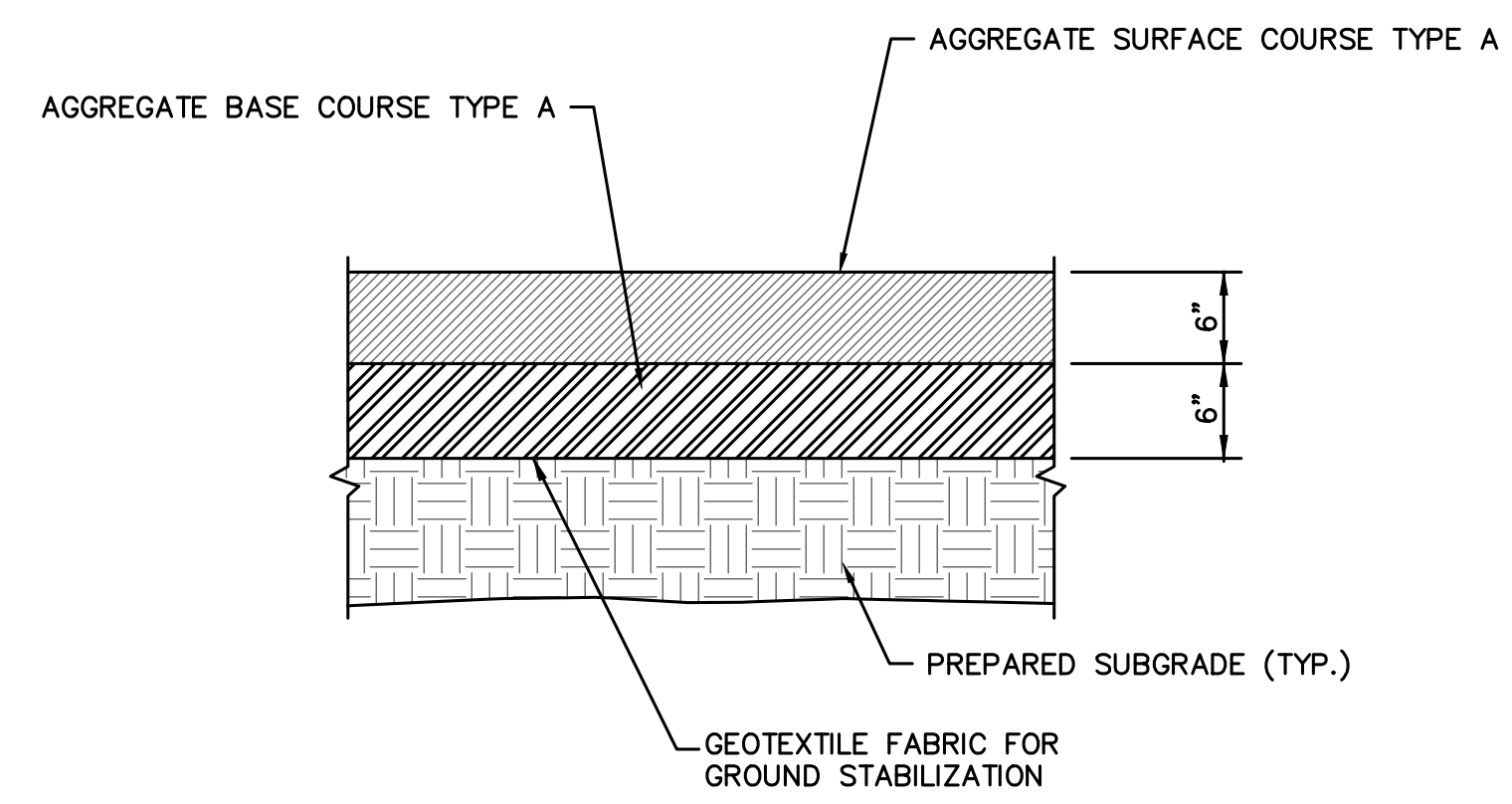
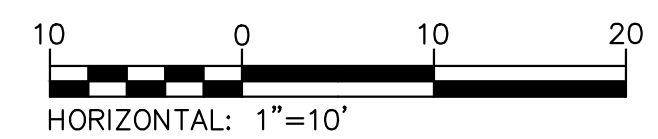
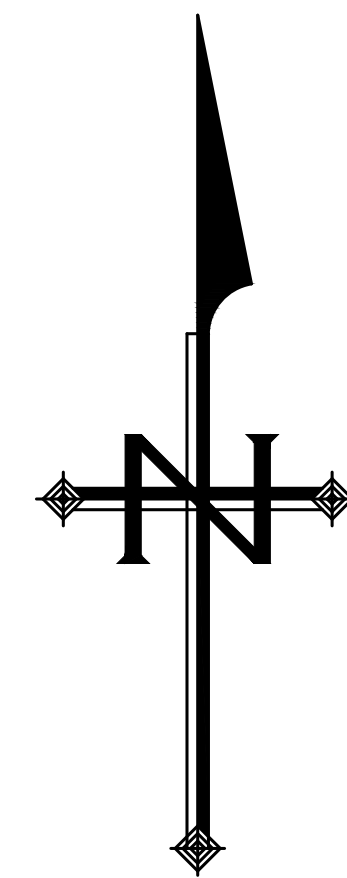
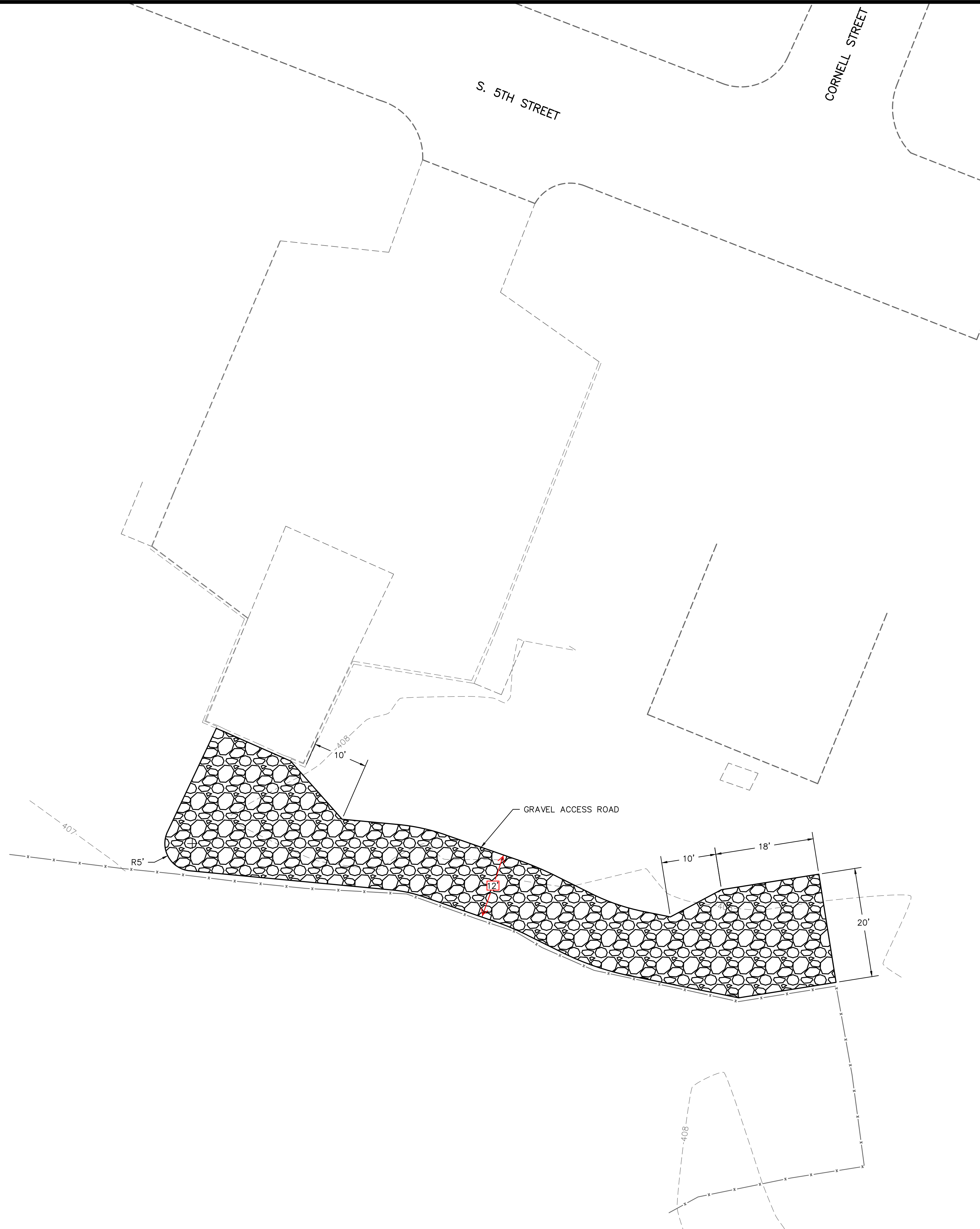

TYPICAL AGGREGATE DRIVE SECTION

NOTES:
 CONSTRUCT WIDE AGGREGATE ACCESS ROAD FROM EXISTING PUMP STATION TO FOLLOW THE FENCELINE AS SHOWN.

HR
 Hurst-Rosche, Inc.
 PROFESSIONAL DESIGN NUMBER: 184-000298
 NO. 5 BANK SQUARE
 EAST ST. LOUIS, IL.
 PH: 618.398.0890
 www.hurst-rosche.com
 HILLSBORO, IL
 SPRINGFIELD, IL
 MARION, IL
 NASHVILLE, TN
 ARNOLD, MO

SIGNATURE
 xx-xx-2022
 DATE 11-30-2023
 LICENSE EXPIRES

SCCHA STREET AND PARKING IMPROVEMENTS
 BROOKLYN, CAHOKIA HEIGHTS, LENZBURG,
 BELLEVILLE AND MILLSTADT
 ST. CLAIR COUNTY, ILLINOIS 62204

MK.	DATE	DESCRIPTION

DATE: APRIL 29, 2024
 PROJECT NO: 280-0474
 DESIGN: SMS DRAWN: JMA CHECK: JLW

BROOKLYN
 SITE PLAN
 AMP 1:1L30-09

C-101

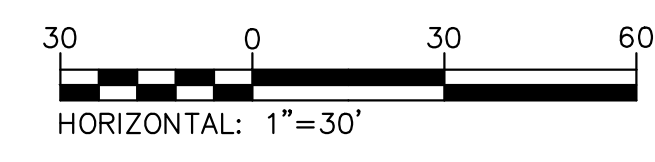
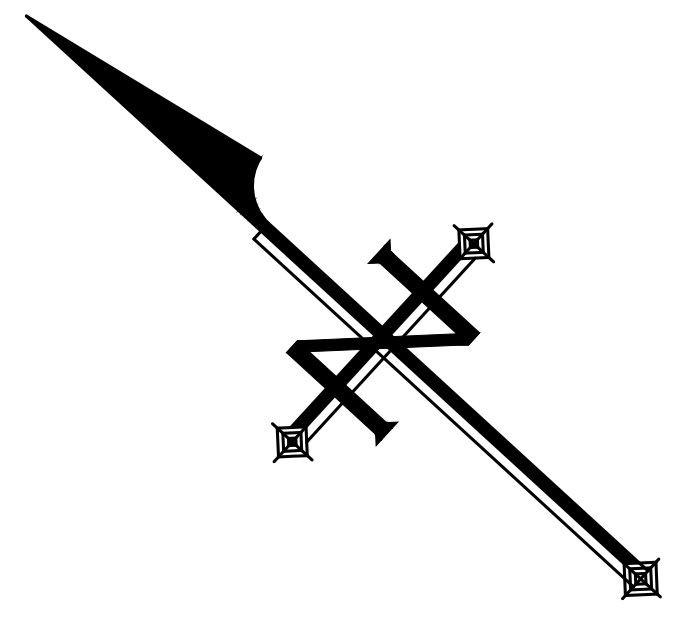
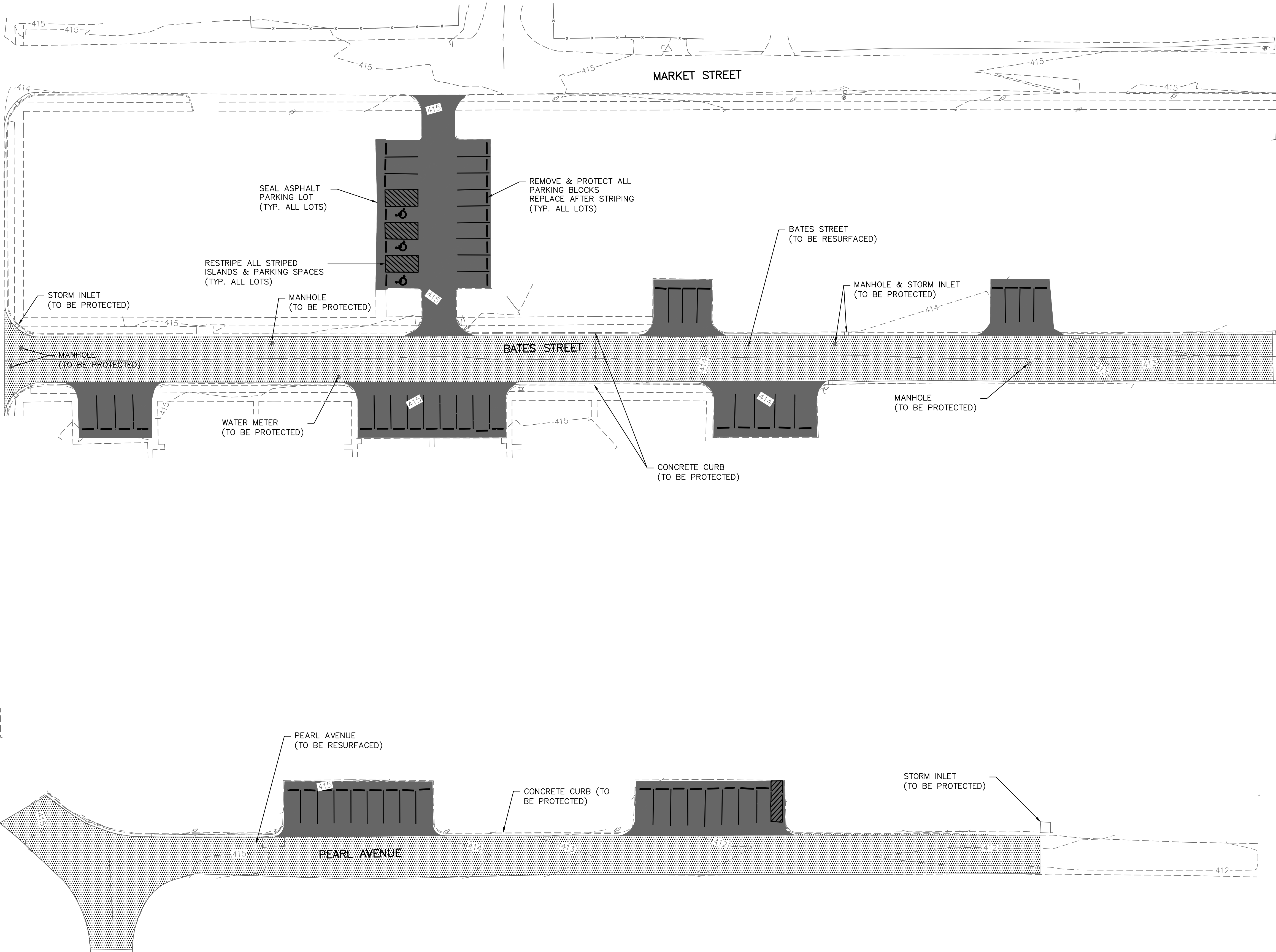

- LEGEND:**
- 1 1/2" HMA SURFACE COURSE
1 1/2" HMA BINDER COURSE
PULVERIZED BASE
PER TYPICAL PAVEMENT REHABILITATION
SECTION ON SHEET G-101
 - RESEAL PARKING LOTS

HR
Hurst-Rosche, Inc.
PROFESSIONAL DESIGN NUMBER: 184-000298
 NO. 5 BANK SQUARE
 EAST ST. LOUIS, IL
 PH: 618.398.0890
 www.hurst-rosche.com
 HILLSBORO, IL
 SPRINGFIELD, IL
 MARION, IL
 NASHVILLE, TN
 ARNOLD, MO

SIGNATURE _____
 xx-xx-2022
 DATE 11-30-2023
 LICENSE EXPIRES

SCCHA STREET AND PARKING IMPROVEMENTS
BROOKLYN, CAHOKIA HEIGHTS, LENZBURG,
BELLEVILLE AND MILLSTADT
ST. CLAIR COUNTY, ILLINOIS 62204

MK.	DATE	DESCRIPTION

DATE: APRIL 29, 2024
 PROJECT NO: 280-0474
 DESIGN: SMS DRAWN: JMA CHECK: JLJ

CAHOKIA HEIGHTS
 SITE PLAN
 AMP 3: IL30-06

C-102

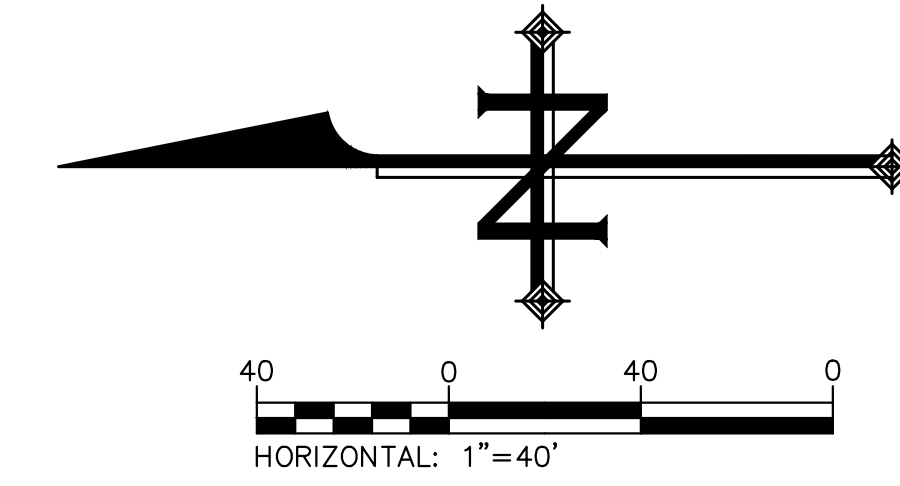

- LEGEND:**
- 1½" HMA SURFACE COURSE
1½" HMA BINDER COURSE
PULVERIZED BASE
PER TYPICAL PAVEMENT REHABILITATION SECTION ON SHEET G-101
 - RESEAL PARKING LOTS

HR
 Hurst-Rosche, Inc.
PROFESSIONAL DESIGN NUMBER: 184-000236
 NO. 5 BANK SQUARE
 EAST ST. LOUIS, IL
 PH: 618.398.0890
 www.hurst-rosche.com
 HILLSBORO, IL
 SPRINGFIELD, IL
 MARION, IL
 NASHVILLE, TN
 ARNOLD, MO

SIGNATURE _____
 xx-xx-2022
 DATE 11-30-2023
 LICENSE EXPIRES _____

SCCHA STREET AND PARKING IMPROVEMENTS
 BROOKLYN, CAHOKIA HEIGHTS, LENZBURG,
 BELLEVILLE AND MILLSTADT
 ST. CLAIR COUNTY, ILLINOIS 62204

MK.	DATE	DESCRIPTION

DATE: APRIL 29, 2024
 PROJECT NO: 280-0474
 DESIGN: SMS DRAWN: JMA CHECK: JLW

CAHOKIA HEIGHTS
 SITE PLAN
 AMP 2: IL 30-10

C-103

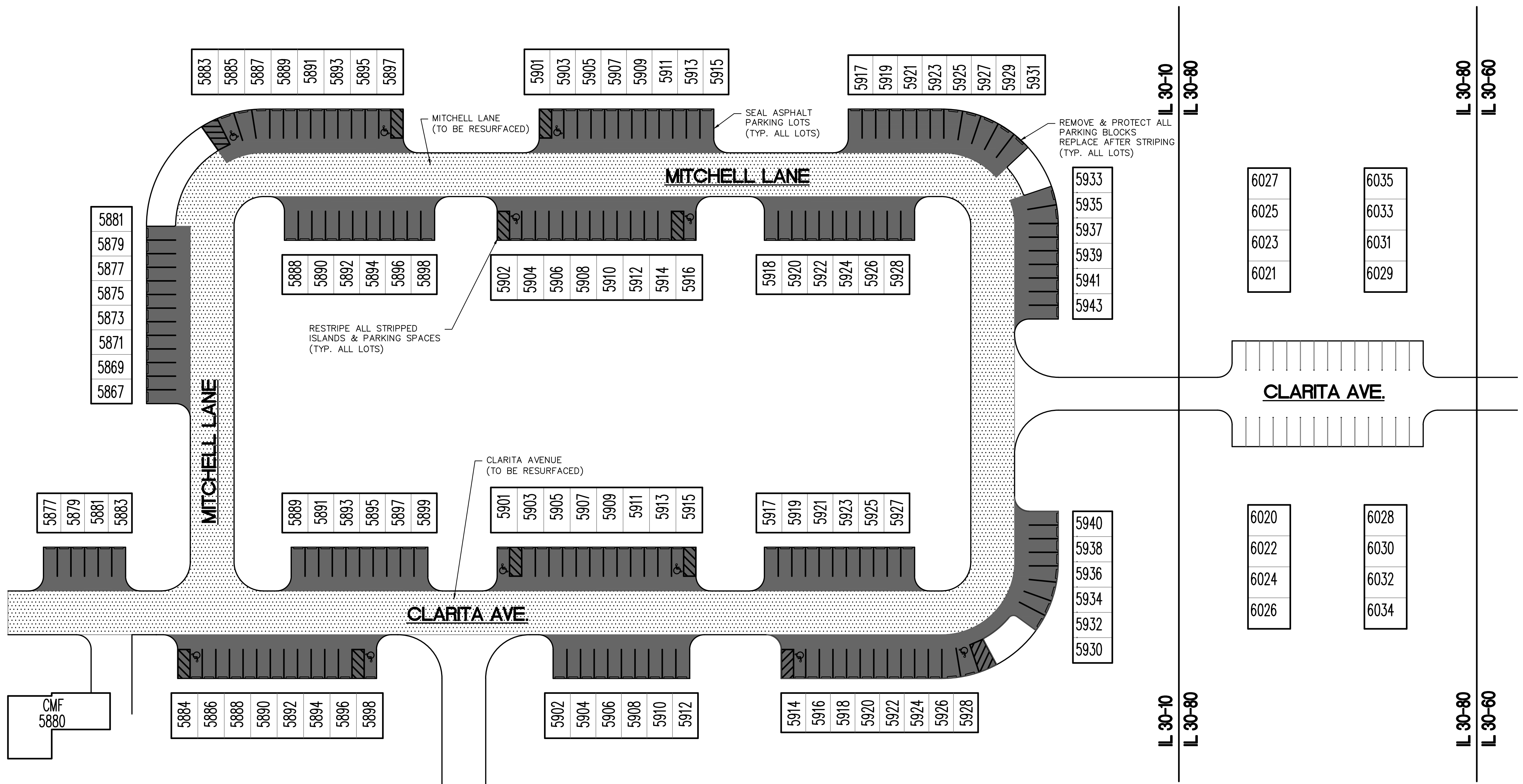

5881
5879
5877
5875
5873
5871
5869
5867

5883
5885
5887
5889
5891
5893
5895
5897

5901
5903
5905
5907
5909
5911
5913
5915

5917
5919
5921
5923
5925
5927
5929
5931

5888
5890
5892
5894
5896
5898

5902
5904
5906
5908
5910
5912
5914
5916

5918
5920
5922
5924
5926
5928

5933
5935
5937
5939
5941
5943

6027
6025
6023
6021

6035
6033
6031
6029

5877
5879
5881
5883

5889
5891
5893
5895
5897
5899

5901
5903
5905
5907
5909
5911
5913
5915

5917
5919
5921
5923
5925
5927

5940
5938
5936
5934
5932
5930

6020
6022
6024
6026

6028
6030
6032
6034

5884
5886
5888
5890
5892
5894
5896
5898

5902
5904
5906
5908
5910
5912

5914
5916
5918
5920
5922
5924
5926
5928

CMF
5880

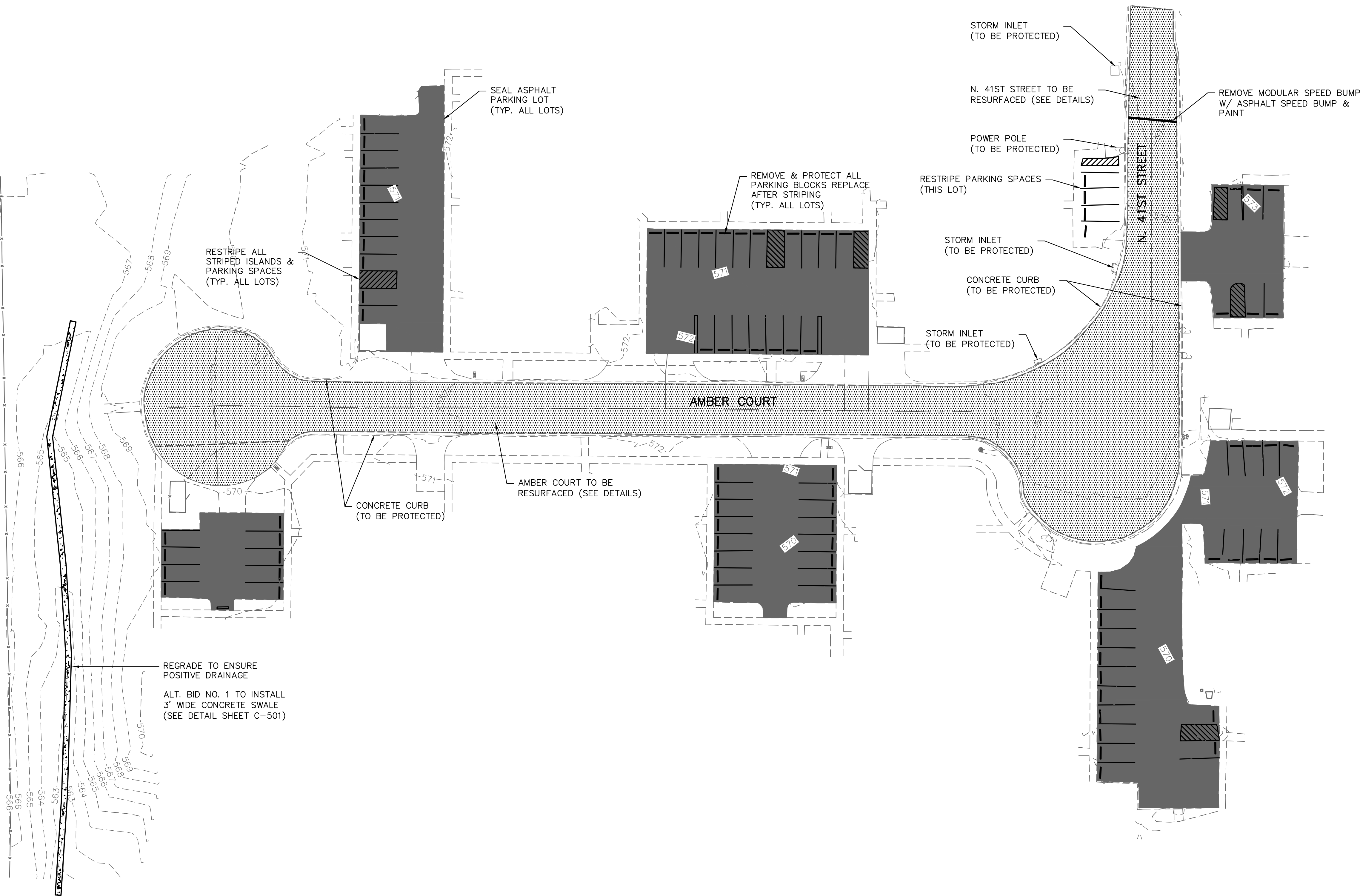

HR
Hurst-Rosche, Inc.
PROFESSIONAL DESIGN NUMBER: 184-000298
 NO. 5 BANK SQUARE
 EAST ST. LOUIS, IL.
 PH: 618.398.0890
 www.hurst-rosche.com
 HILLSBORO, IL
 SPRINGFIELD, IL
 MARION, IL
 NASHVILLE, TN
 ARNOLD, MO

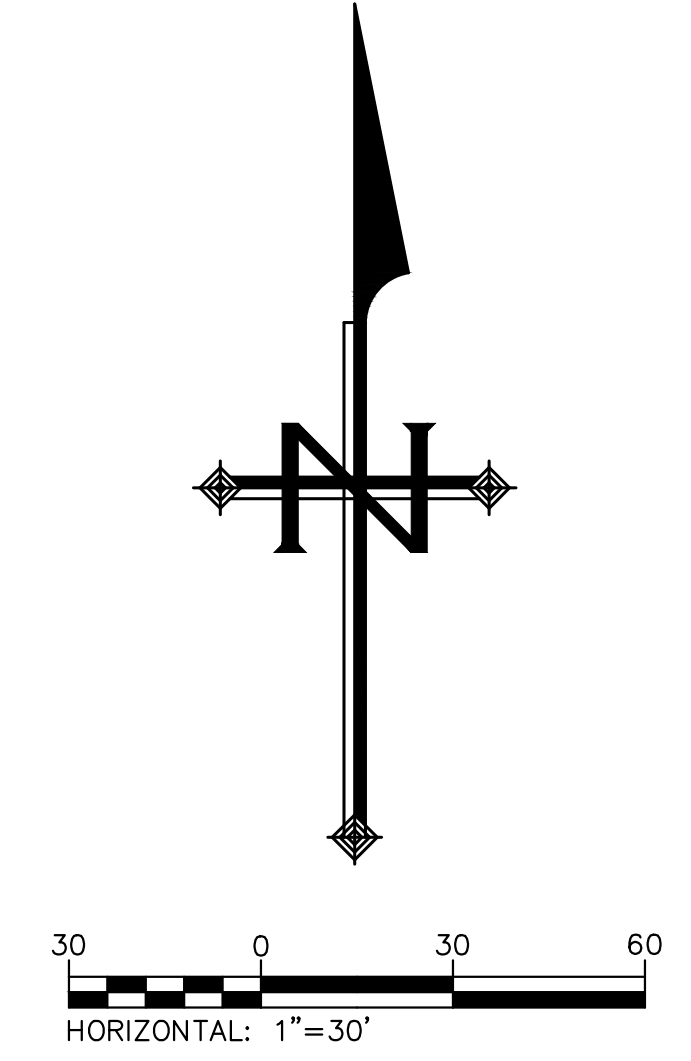

SIGNATURE
 xx-xx-2022
 DATE 11-30-2023
 LICENSE EXPIRES

LEGEND:
 1 1/2" HMA SURFACE COURSE
 1 1/2" HMA BINDER COURSE
 PULVERIZED BASE
 PER TYPICAL PAVEMENT REHABILITATION
 SECTION ON SHEET G-101
 RESEAL PARKING LOTS

SCCHA STREET AND PARKING IMPROVEMENTS
BROOKLYN, CAHOKIA HEIGHTS, LENZBURG,
BELLEVILLE AND MILLSTADT
ST. CLAIR COUNTY, ILLINOIS 62204

MK.	DATE	DESCRIPTION

DATE: APRIL 29, 2024
 PROJECT NO: 280-0474
 DESIGN: SMS DRAWN: JMA CHECK: JLJ

BELLEVILLE
 SITE PLAN
 AMP 4: IL30-27

C-104

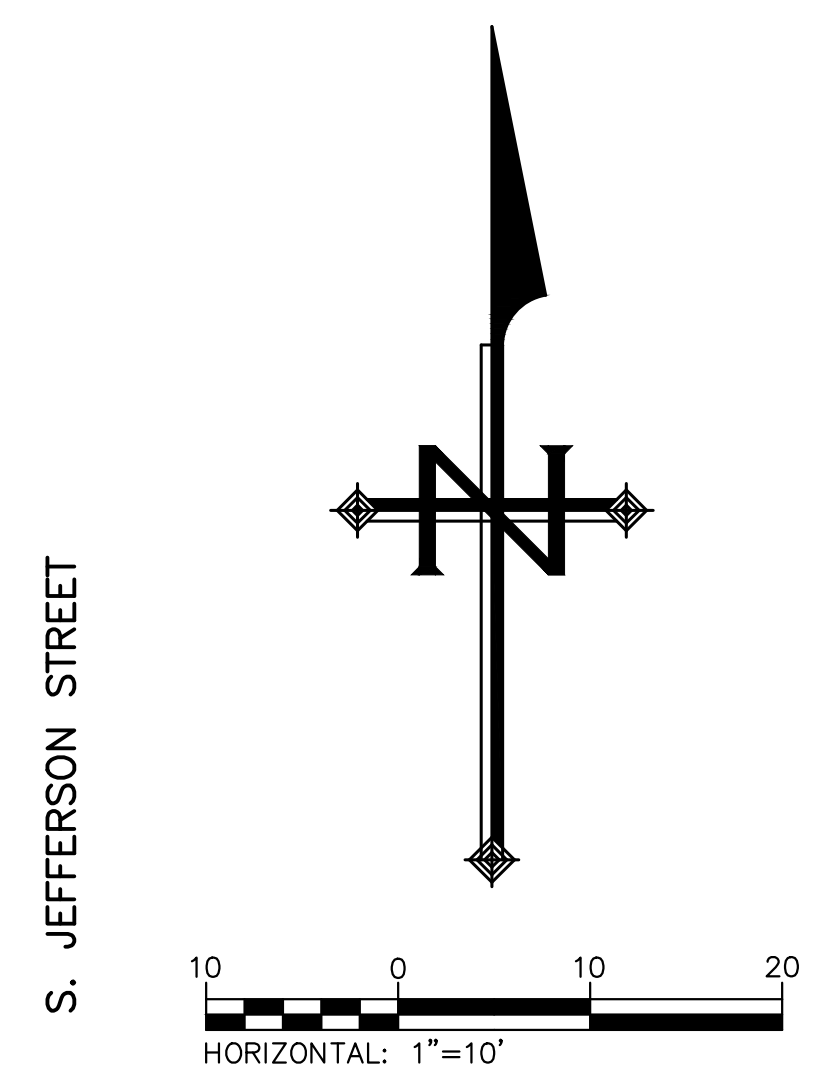
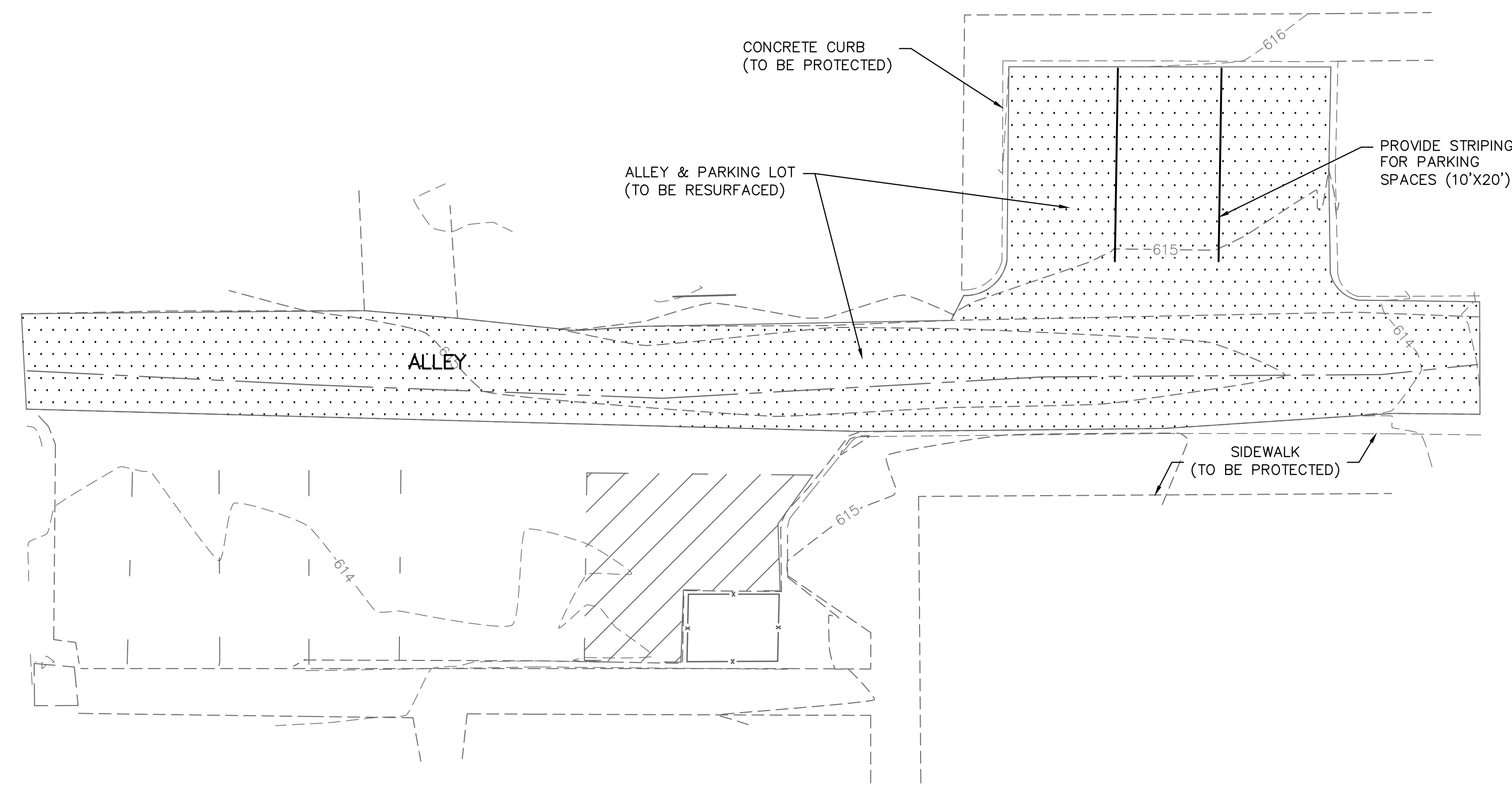

- LEGEND:**
- 1 1/2" HMA SURFACE COURSE
 - 1 1/2" HMA BINDER COURSE
 - PULVERIZED BASE
 - PER TYPICAL PAVEMENT REHABILITATION SECTION ON SHEET G-101
 - 6" PCC OVER 6" COMPACTED AGGREGATE BASE

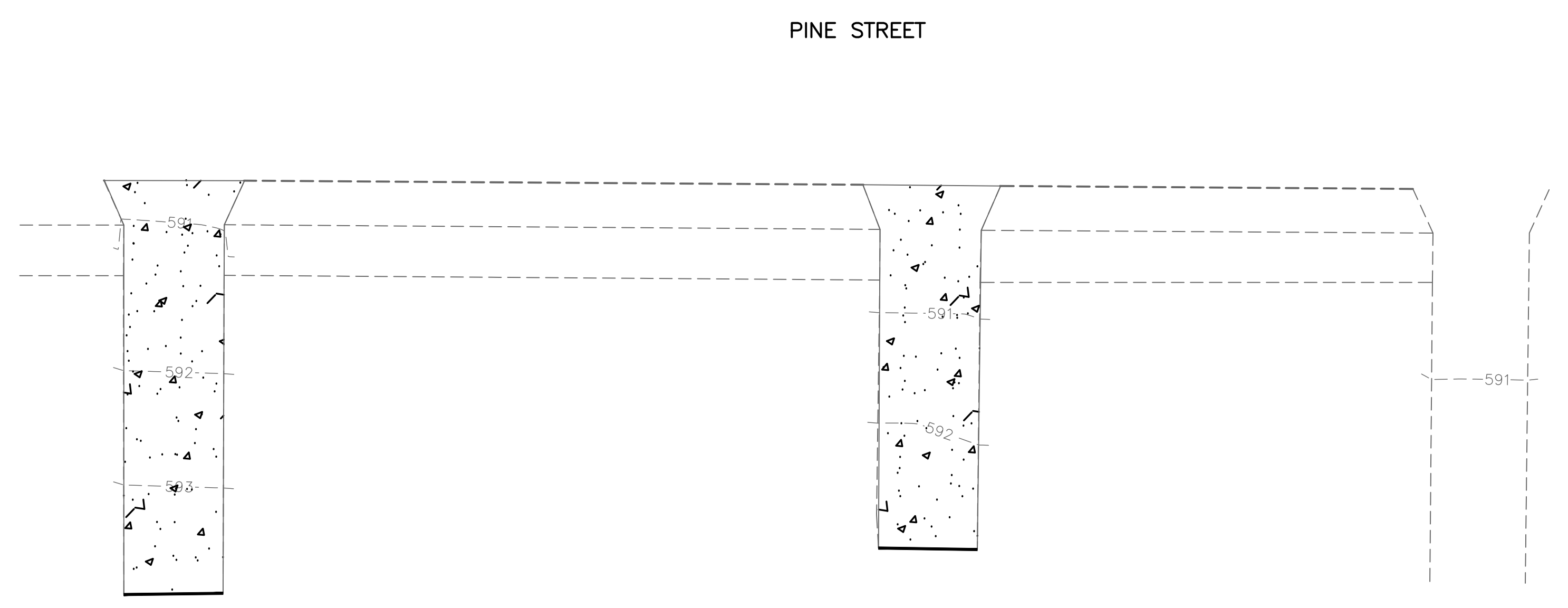
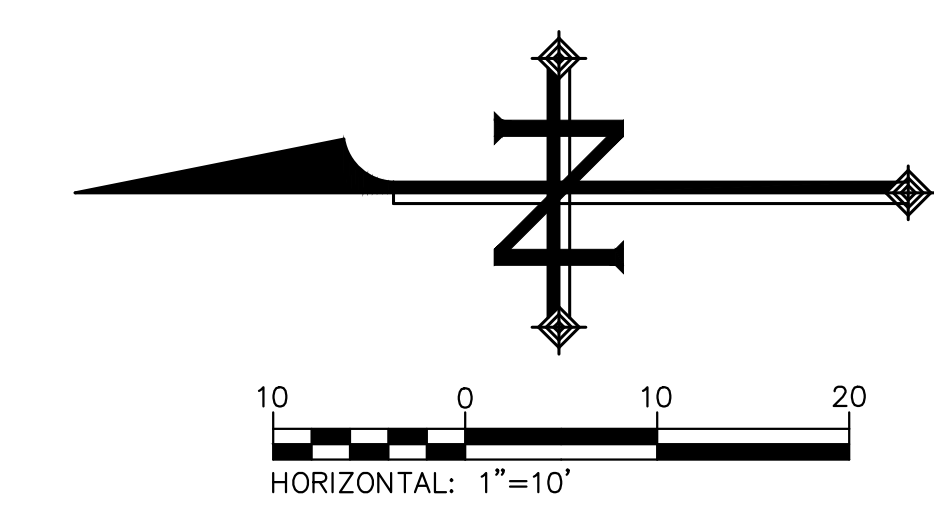
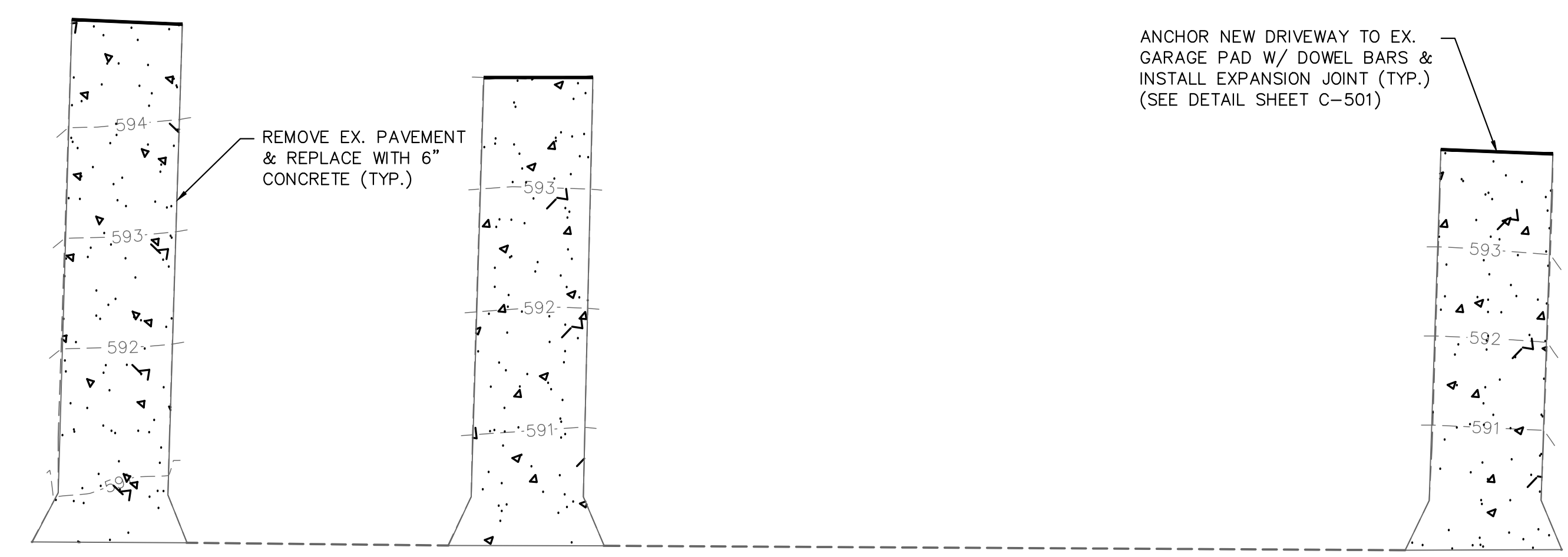

Hurst-Rosche, Inc.
PROFESSIONAL DESIGN NUMBER: 184-000268
 NO. 5 BANK SQUARE
 EAST ST. LOUIS, IL
 PH: 618.398.0890
 www.hurst-rosche.com
 HILLSBORO, IL
 SPRINGFIELD, IL
 MARION, IL
 NASHVILLE, TN
 ARNOLD, MO

SIGNATURE
 xx-xx-2022
 DATE 11-30-2023
 LICENSE EXPIRES

SCCHA STREET AND PARKING IMPROVEMENTS
 BROOKLYN, CAHOKIA HEIGHTS, LENZBURG,
 BELLEVILLE AND MILLSTADT
 ST. CLAIR COUNTY, ILLINOIS 62204

MK.	DATE	DESCRIPTION

DATE: APRIL 29, 2024
 PROJECT NO: 280-0474
 DESIGN: SMS DRAWN: JMA CHECK: JLV

MILLSTADT
 SITE PLAN
 AMP 6: IL30-22

C-105



Hurst-Rosche, Inc.
PROFESSIONAL DESIGN NUMBER: 184-000298

NO. 5 BANK SQUARE
EAST ST. LOUIS, IL
PH: 618.398.0890

www.hurst-rosche.com

HILLSBORO, IL
SPRINGFIELD, IL
MARION, IL
NASHVILLE, TN
ARNOLD, MO

SIGNATURE

xx-xx-2022

DATE 11-30-2023

LICENSE EXPIRES

SCCHA STREET AND PARKING IMPROVEMENTS
BROOKLYN, CAHOKIA HEIGHTS, LENZBURG,
BELLEVILLE AND MILLSTADT
ST. CLAIR COUNTY, ILLINOIS 62204

MK.	DATE	DESCRIPTION

LENZBURG
SITE PLAN
AMP 6: IL30-19, IL30-28

C-106

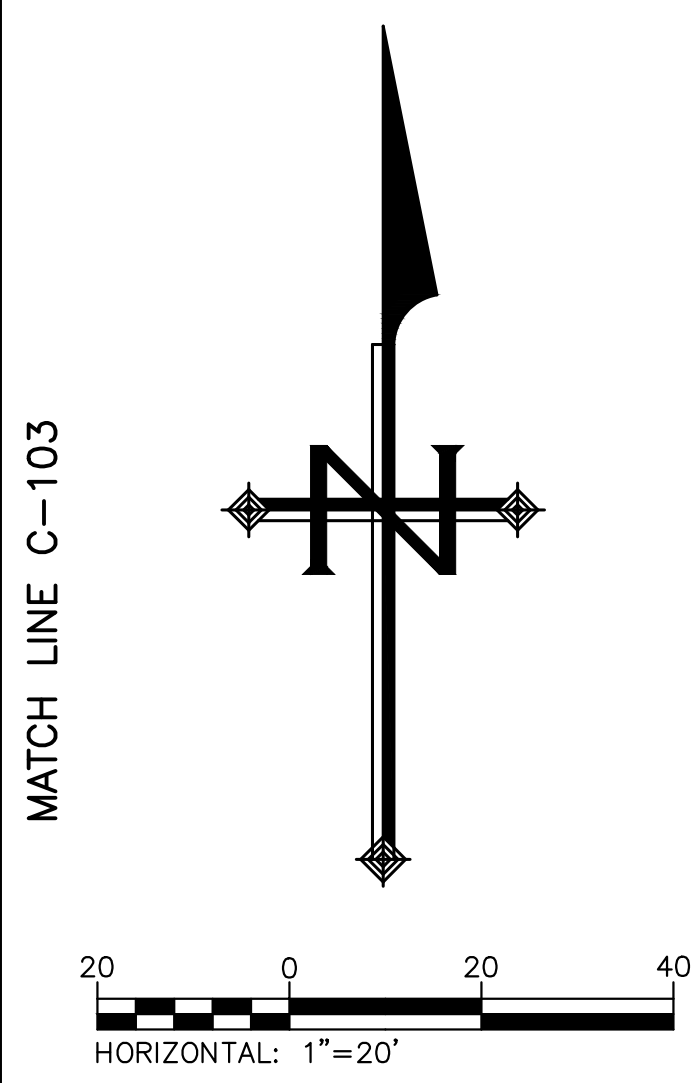
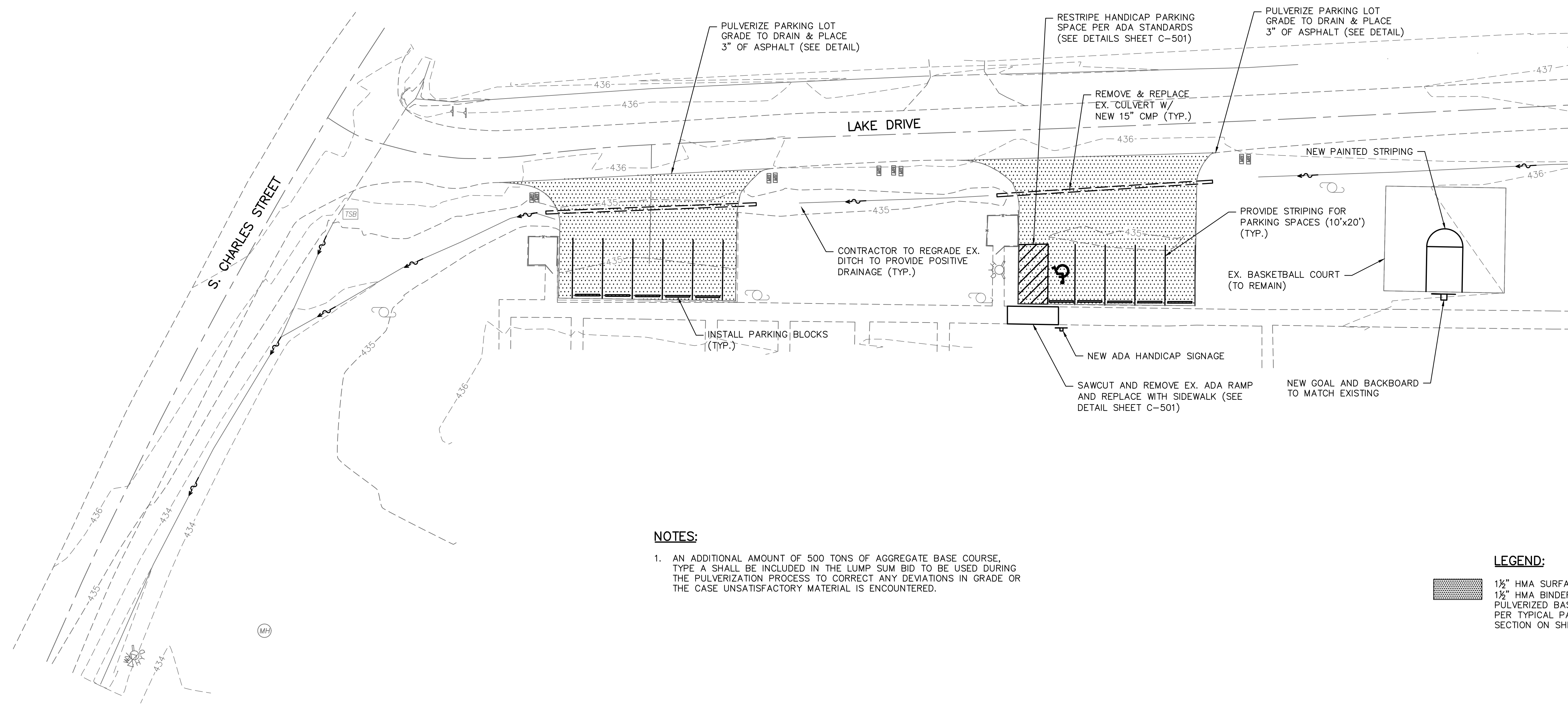

NOTES:

1. AN ADDITIONAL AMOUNT OF 500 TONS OF AGGREGATE BASE COURSE, TYPE A SHALL BE INCLUDED IN THE LUMP SUM BID TO BE USED DURING THE PULVERIZATION PROCESS TO CORRECT ANY DEVIATIONS IN GRADE OR THE CASE UNSATISFACTORY MATERIAL IS ENCOUNTERED.

LEGEND:

- 1 1/2" HMA SURFACE COURSE
- 1 1/2" HMA BINDER COURSE
- PULVERIZED BASE
- PER TYPICAL PAVEMENT REHABILITATION SECTION ON SHEET G-101

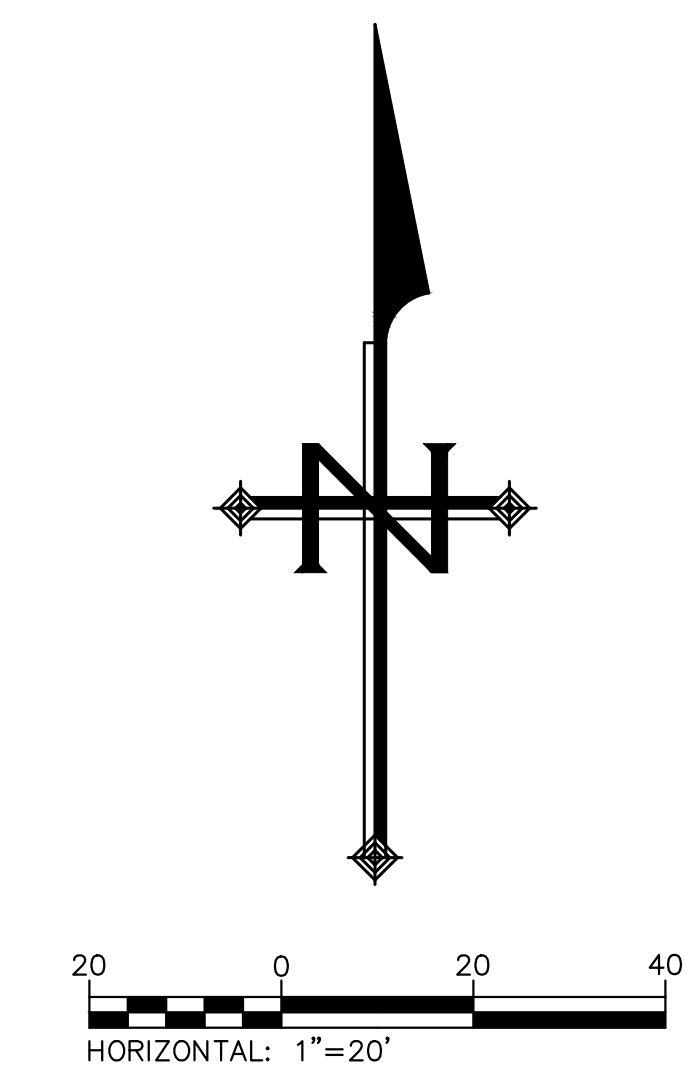
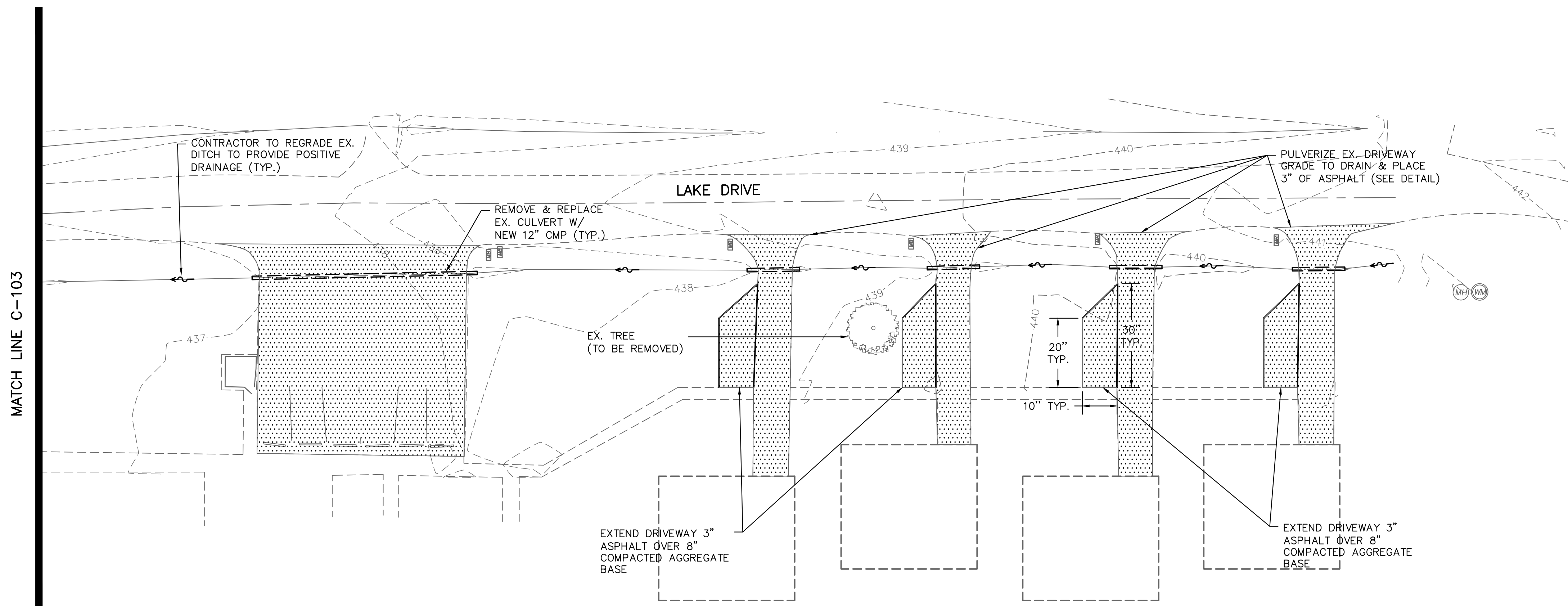

MATCH LINE C-103

MATCH LINE C-103

SIGNATURE
 xx-xx-2022
 DATE 11-30-2023
 LICENSE EXPIRES

SCCHA STREET AND PARKING IMPROVEMENTS
BROOKLYN, CAHOKIA HEIGHTS, LENZBURG,
BELLEVILLE AND MILLSTADT
ST. CLAIR COUNTY, ILLINOIS 62204

MK.	DATE	DESCRIPTION

DATE: APRIL 29, 2024
 PROJECT NO: 280-0474
 DESIGN: SMS DRAWN: JMA CHECK: JLJ
 MISCELLANEOUS DETAILS

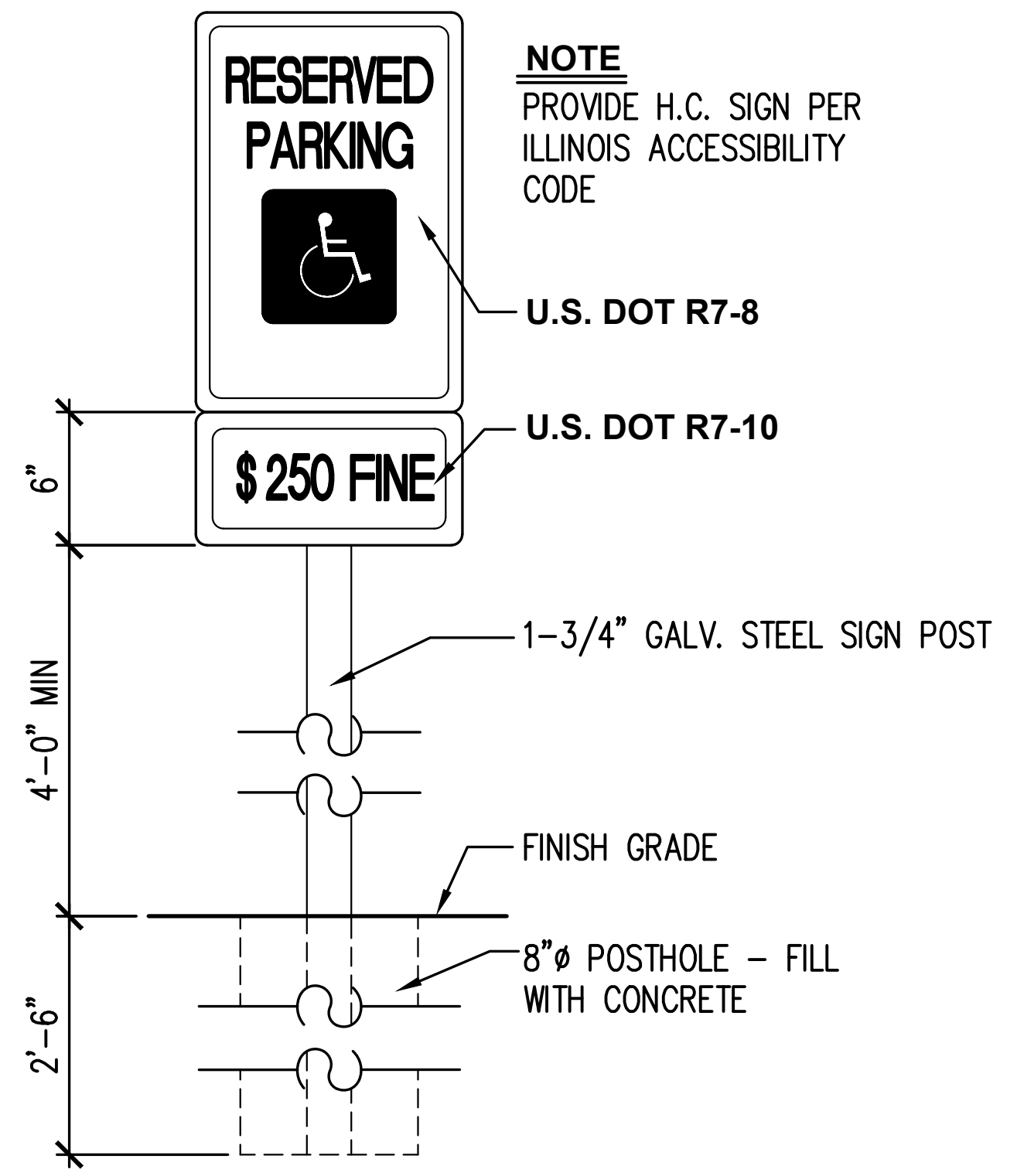

HANDICAP SIGN DETAIL
 NOT TO SCALE

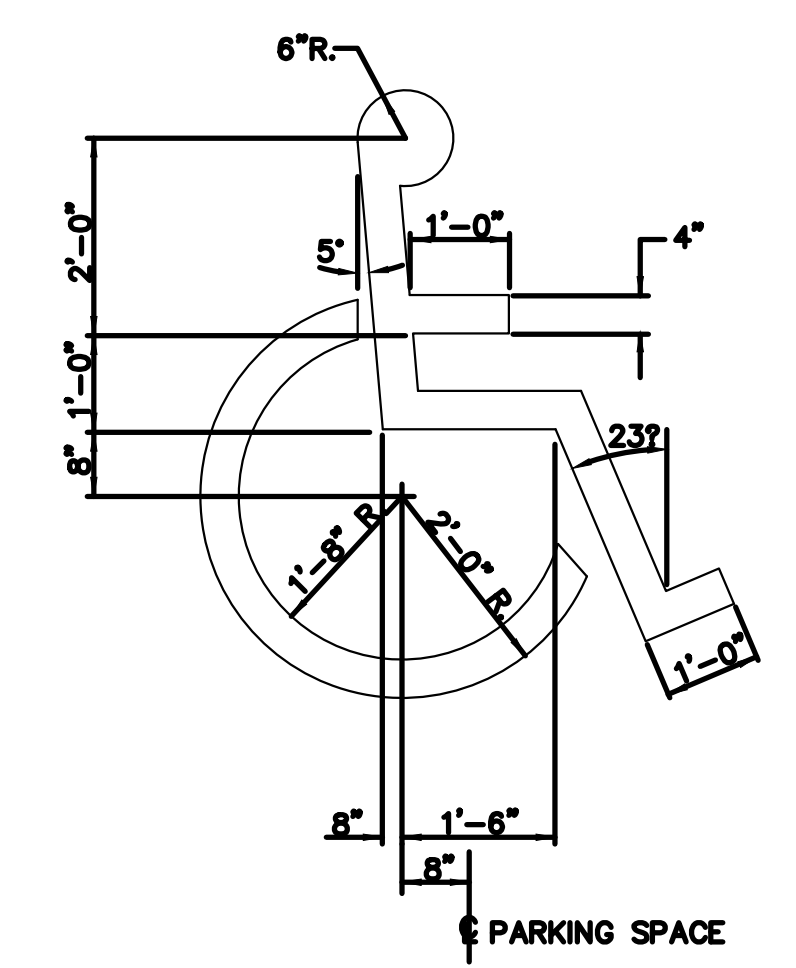

INTERNATIONAL HANDICAP SYMBOL
 NOT TO SCALE

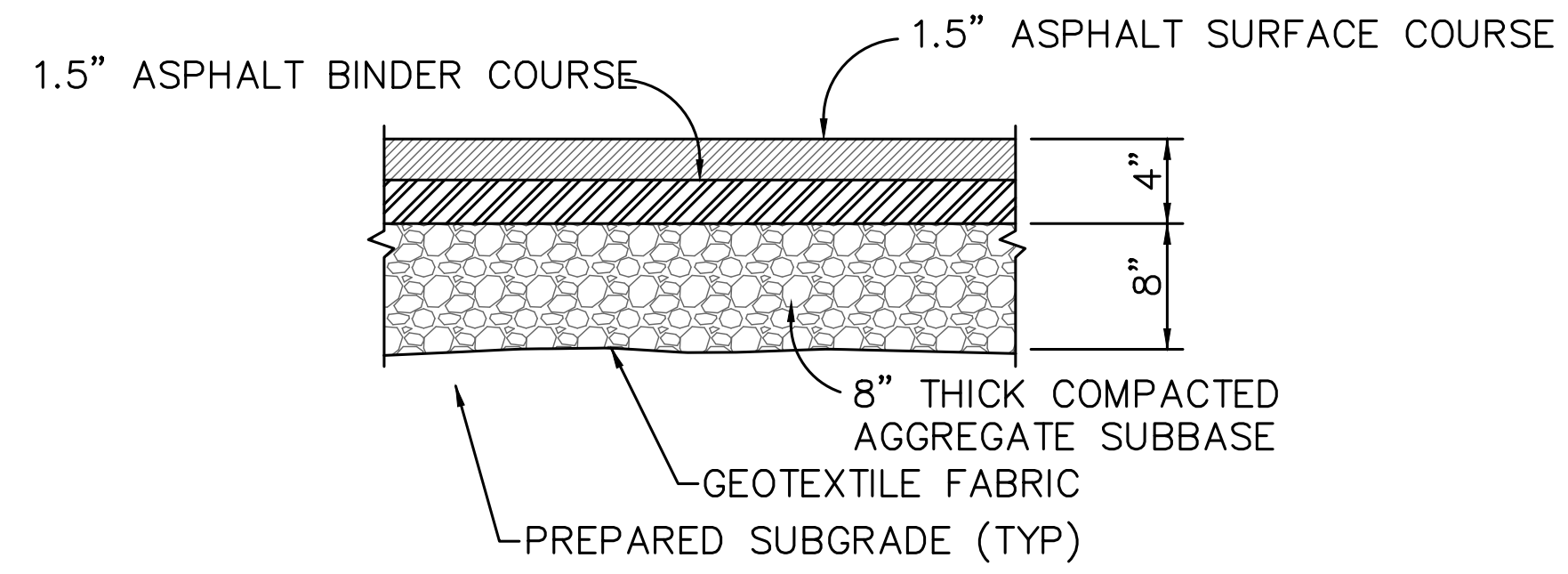

ASPHALT PAVEMENT SECTION FOR PARKING LOT
 NOT TO SCALE

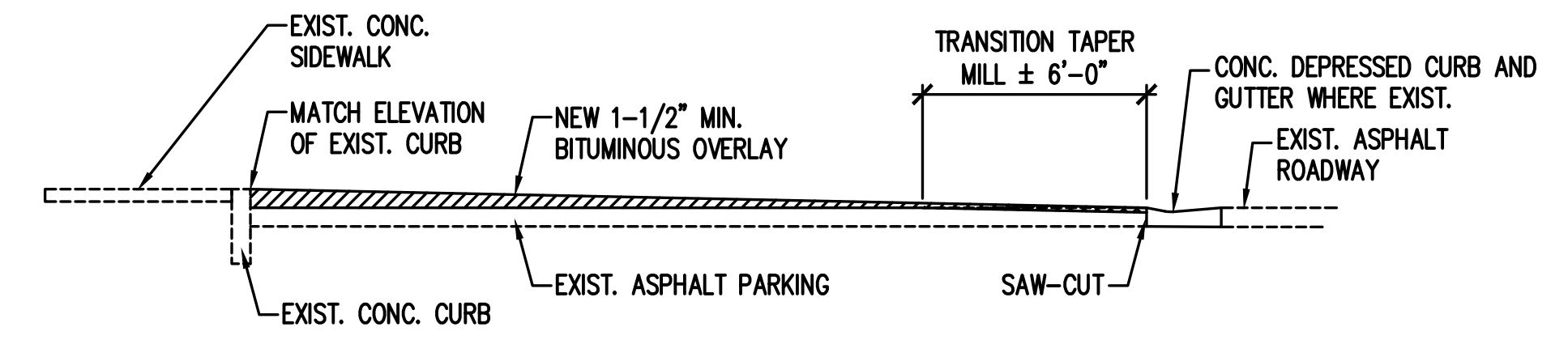

TYPICAL TAPERED HMA PARKING SECTION
 NOT TO SCALE

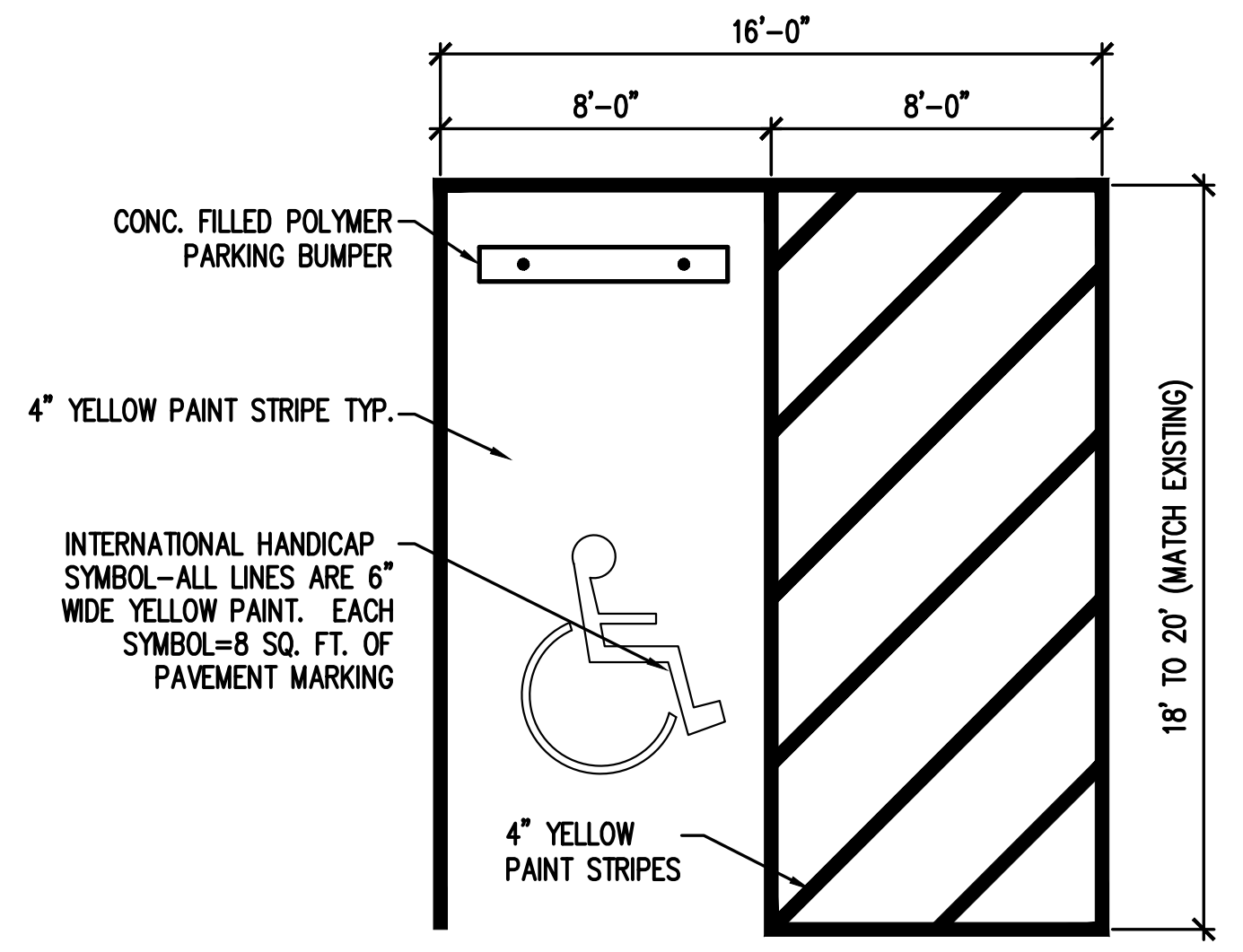

TYPICAL HANDICAP PARKING DETAIL
 NOT TO SCALE

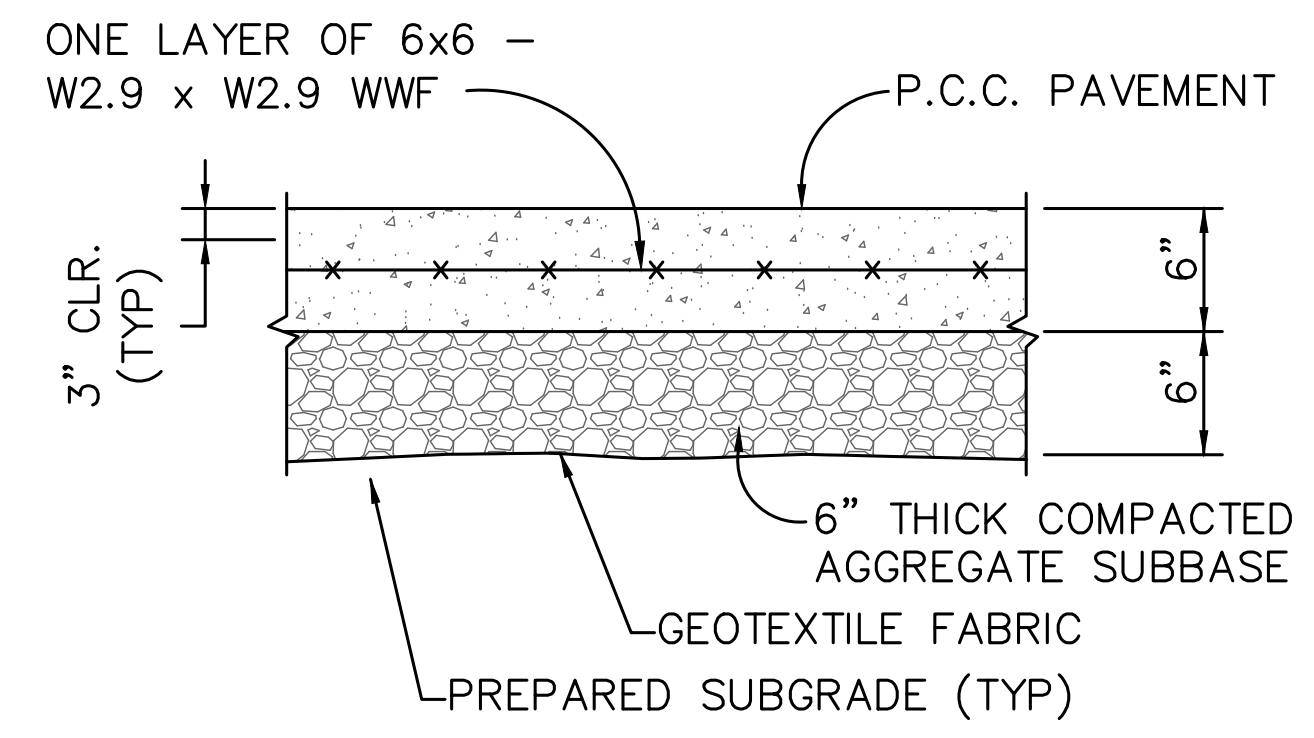

CONCRETE PAVEMENT SECTION FOR PARKING LOT
 NOT TO SCALE

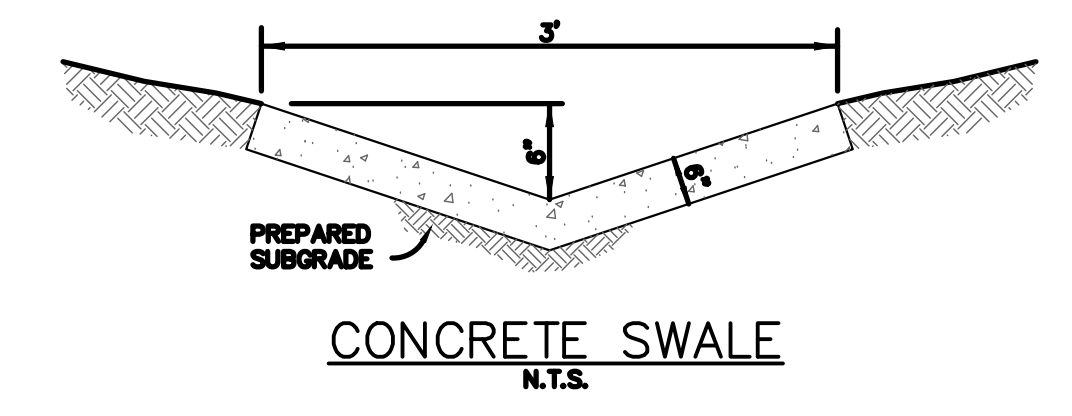

CONCRETE SWALE
 N.T.S.

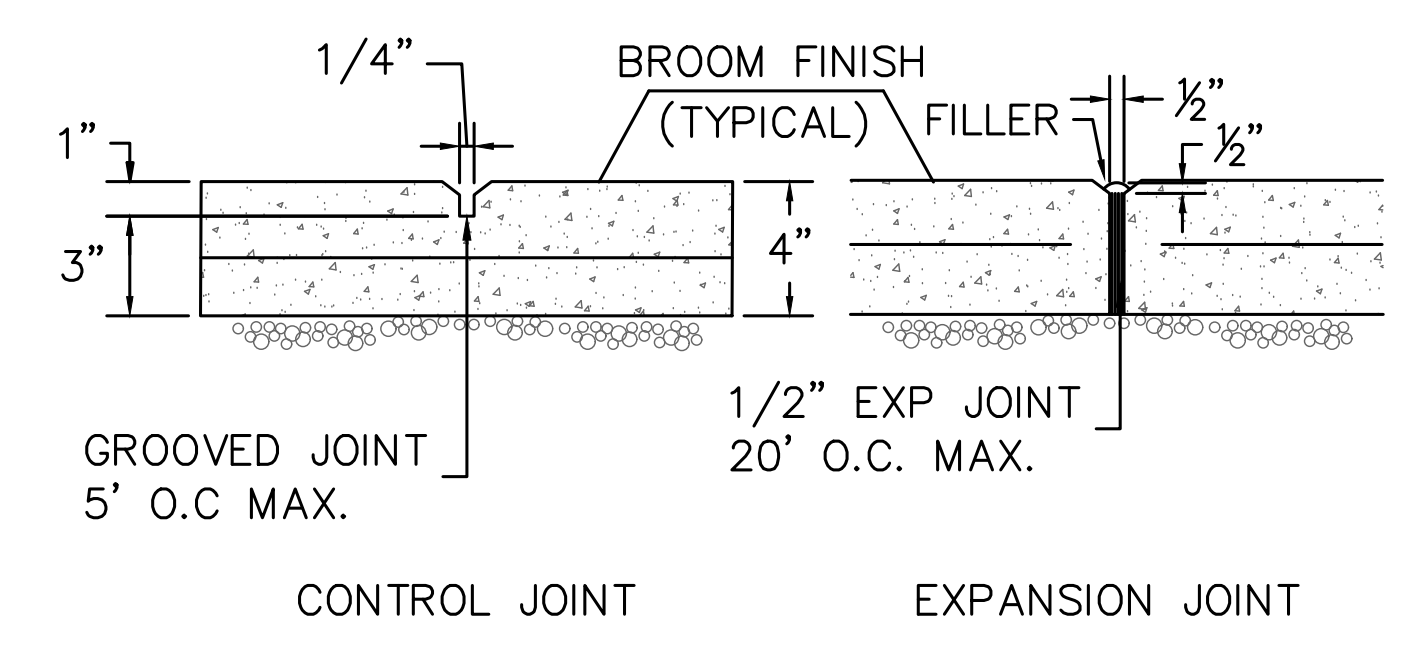

TYPICAL SIDEWALK JOINTS
 NOT TO SCALE

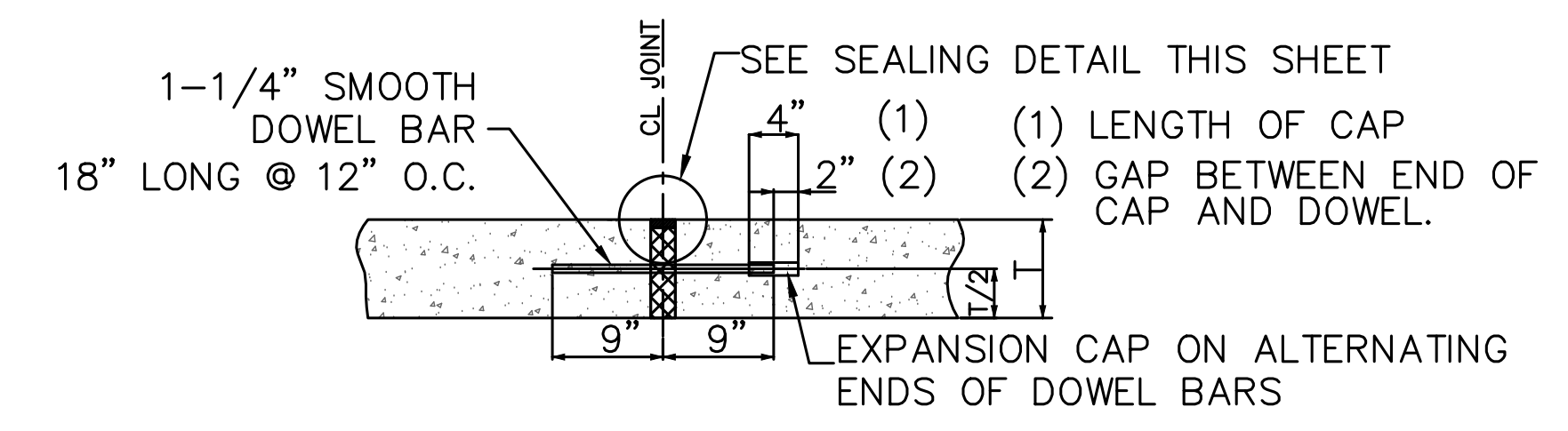

EXPANSION JOINT
 NOT TO SCALE

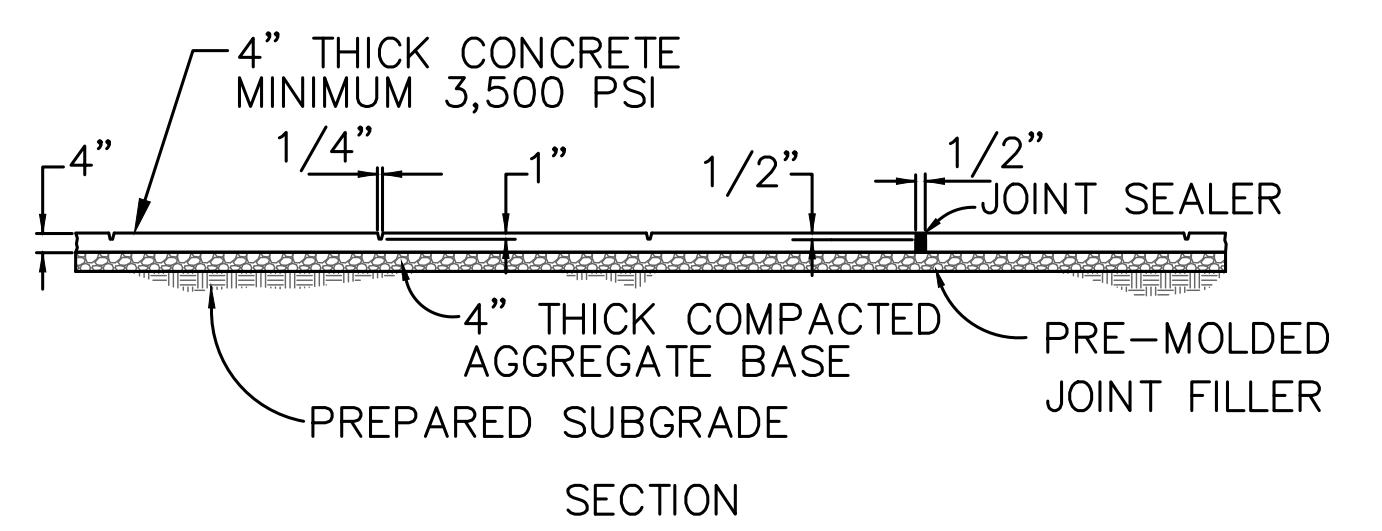
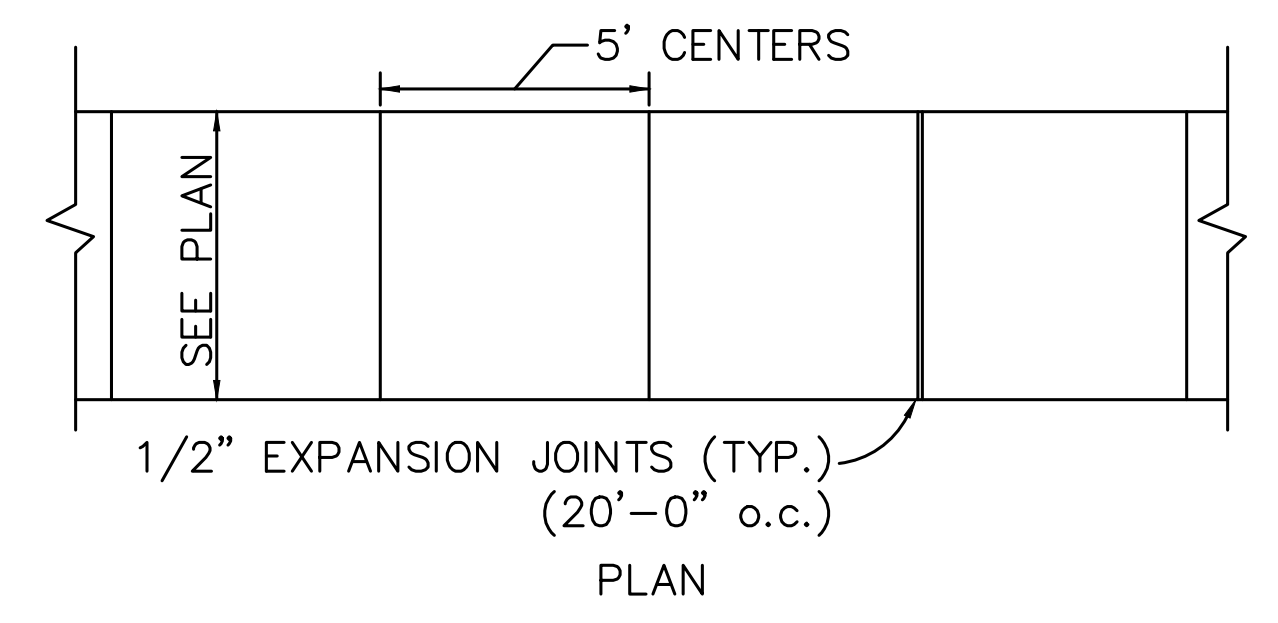

CONCRETE SIDEWALK DETAIL
 NOT TO SCALE