

BIDDING AND CONTRACT DOCUMENTS
ADDENDUM NO. 3

DATE: June 18, 2024

Hurst-Rosche, Inc.
1101 Kermit Drive, Suite 620
Nashville, Tennessee 37217

TO: PROSPECTIVE BIDDERS

SUBJECT: ADDENDUM NO. 3 TO THE BIDDING DOCUMENTS FOR

Montgomery Bell State Park Four Mile Creek Campground Renovation
Montgomery Bell State Park
Burns, Dickson County, Tennessee
SBC No. 126/054-01-2022

This addendum forms a part of the bidding and contract documents and modifies the bidding documents dated April 24, 2024. Acknowledge receipt of this addendum in space provided on Bid Form.

.....

CLARIFICATIONS



1. Addendum No. 2 error.

a. Error with noted bid due date. Correction:

Change: “This addendum **DOES NOT** alter the previously published bid due date of **June 10th, 2024, 02:00 pm, at Central Procurement Office, located at William R. Snodgrass Tennessee Tower, 3rd Floor, Nashville, TN 37243-1102.**”

To: “This addendum **DOES NOT** alter the previously published bid due date of **July 10th, 2024, 02:00 pm, at Central Procurement Office, located at William R. Snodgrass Tennessee Tower, 3rd Floor, Nashville, TN 37243-1102.**”

RFI RESPONSES



2. Questions about the power pedestals located at each campsite: Are we reusing the existing or replacing them?

a. Revise Drawing **E-101** (Montgomery Bell State Park Proposed Site Electrical 1).

Add General Note: “SALVAGE AND REUSE EXISTING ELECTRICAL PEDESTALS.”

b. Revise Drawing **E-102** (Montgomery Bell State Park Proposed Site Electrical 2).

Add General Note: “SALVAGE AND REUSE EXISTING ELECTRICAL PEDESTALS.”

- c. Revise Drawing **E-103** (Montgomery Bell State Park Proposed Site Electrical 3).

Add General Note: "SALVAGE AND REUSE EXISTING ELECTRICAL PEDESTALS."

- d. Add Sheet **E-501** (Details).

Add Sheet: E-501 (Details)

This addendum **DOES NOT** alter the previously published bid due date of **July 10th, 2024, 02:00 pm, at Central Procurement Office, located at William R. Snodgrass Tennessee Tower, 3rd Floor, Nashville, TN 37243-1102.**

Respectfully submitted,

HURST-ROSCHE, INC.

Alex Grenhoff
Project Manager



06/18/2024

DATE

03/31/2025

LICENSE EXPIRES

ADDENDUM NO. 3 RECEIVED BY:

Authorized Representative

Company Name

Date



Hurst-Rosche, Inc.
 SECRETARY OF STATE CONTROL NUMBER: 00092303
 1101 KERMIT DR, SUITE 620
 NASHVILLE, TN
 PH: 615.454.6615
 www.hurst-rosche.com
 HILLSBORO, IL
 EAST ST. LOUIS, IL
 MARION, IL
 ARNOLD, MO
 SPRINGFIELD, IL

Peter James Murphy
 SIGNATURE 06-18-2024
 DATE 03-31-2025
 LICENSE EXPIRES

MONTGOMERY BELL STATE PARK FOUR MILE CREEK
 CAMPGROUND RENOVATION
 1020 JACKSON HILL ROAD
 BURNS, DICKSON COUNTY, TENNESSEE
 SBC PROJECT NO. 126/054-01-2022

MARK	DATE	DESCRIPTION
1	6-5-2024	ADDENDUM #2
2	6-18-2024	ADDENDUM #3

DATE: 06-18-2024
 PROJECT NO: 530-0483
 DESIGN: JL DRAWN: JL CHECK: PJM

MONTGOMERY BELL
 STATE PARK
 PROPOSED SITE
 ELECTRICAL 1

E-101

LEGEND

	Q100 FLOODPLAIN BOUNDARY		LIGHT POLE		TREE
	WATER LINE - MAIN		UTILITY POLE		PUMP STATION
	WATER LINE - TO CAMPSITE		POST OR PANEL		
	SANITARY SEWER - MAIN		ELECTRIC LINE (BY ELECTRICAL CONTRACTOR)		
	SANITARY SEWER - TO CAMPSITE		OVERHEAD ELECTRIC		
	BENCH SEAT				
	TRANSFORMER				
	CAMPGROUND SITE NUMBER				

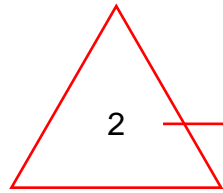

GENERAL NOTES

- SALVAGE AND REUSE EXISTING ELECTRICAL PEDESTALS.

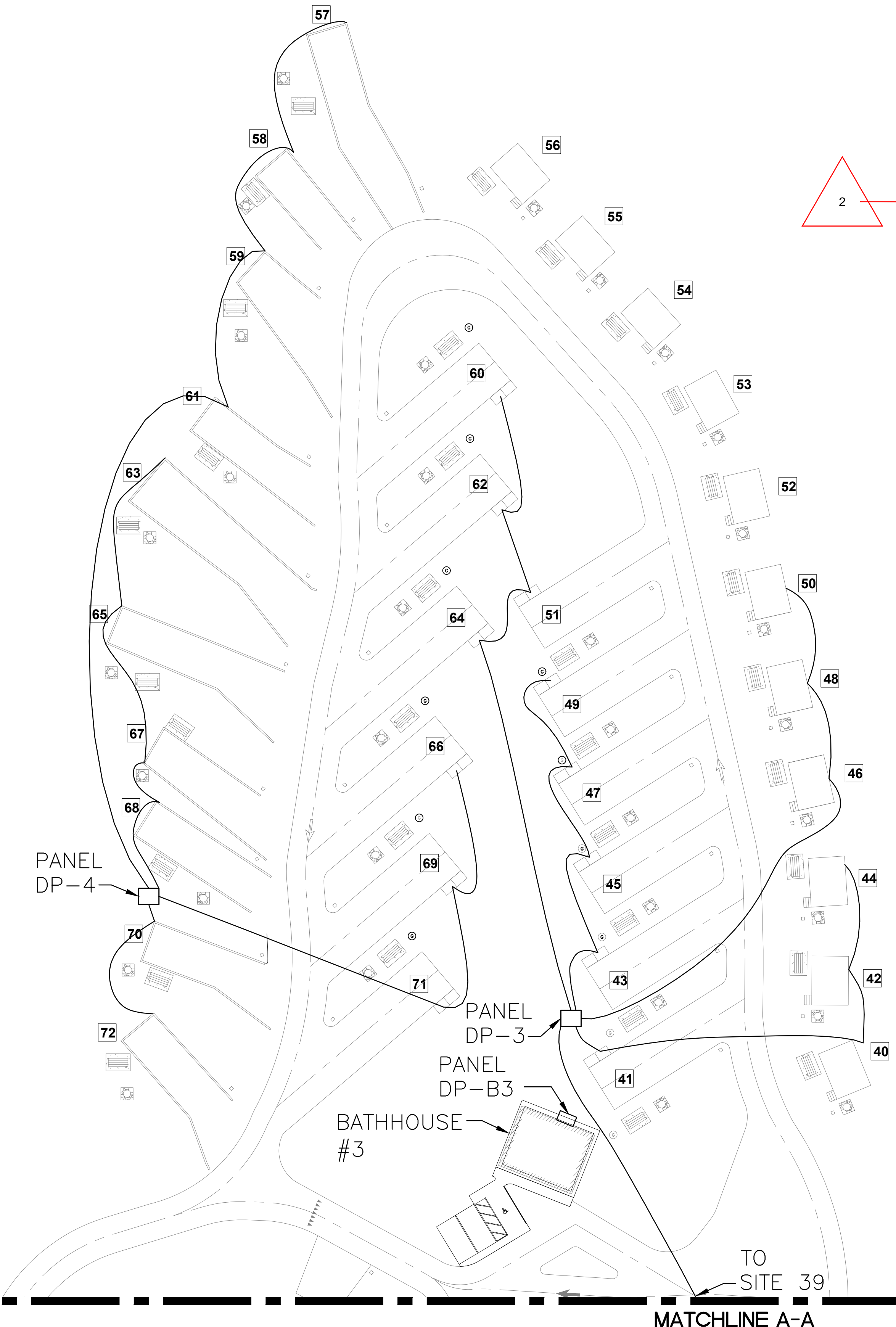

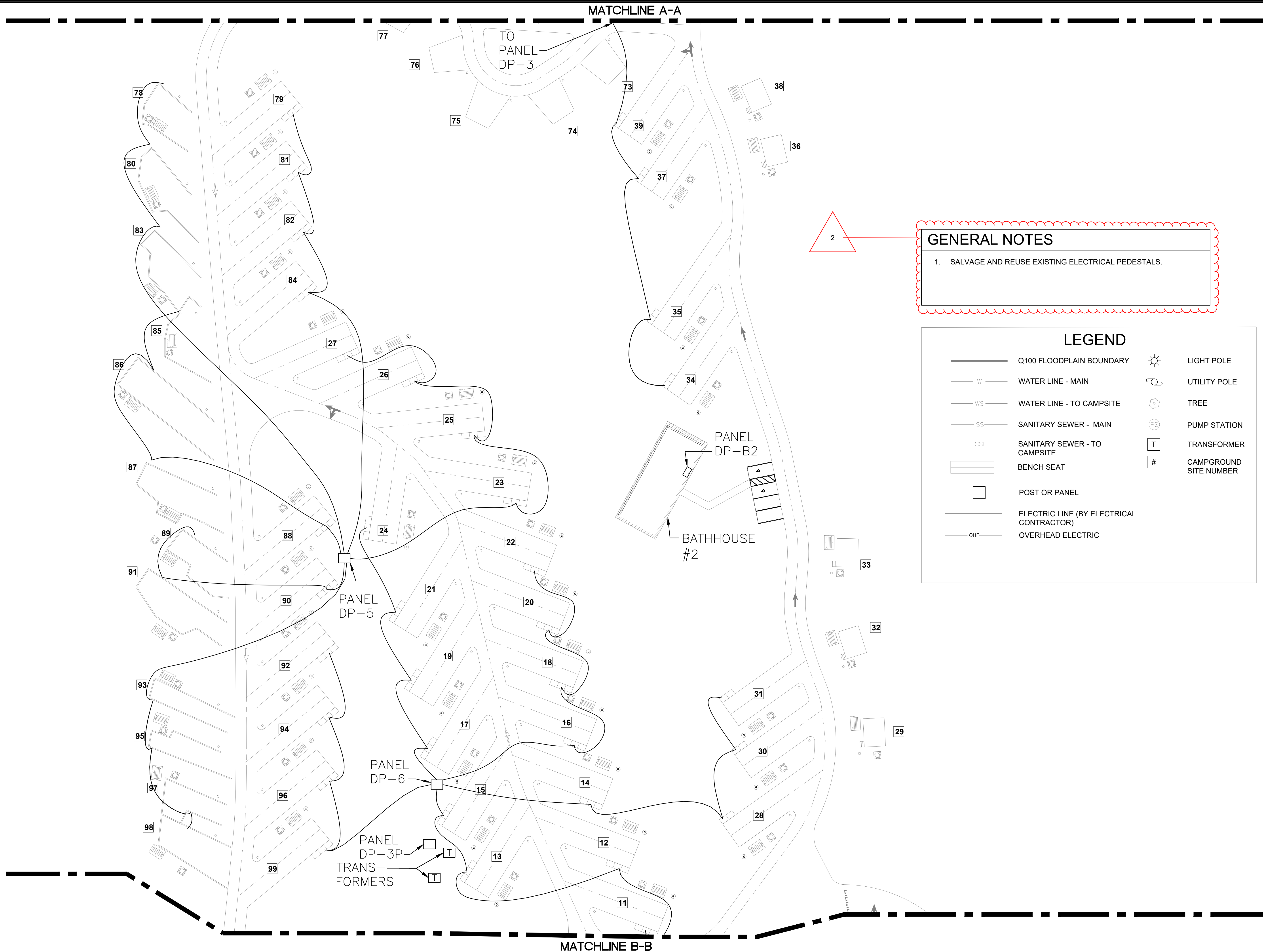

GENERAL NOTES

1. SALVAGE AND REUSE EXISTING ELECTRICAL PEDESTALS.

LEGEND

	Q100 FLOODPLAIN BOUNDARY		LIGHT POLE
	WATER LINE - MAIN		UTILITY POLE
	WATER LINE - TO CAMPSITE		TREE
	SANITARY SEWER - MAIN		PUMP STATION
	SANITARY SEWER - TO CAMPSITE		TRANSFORMER
	BENCH SEAT		CAMPGROUND SITE NUMBER
	POST OR PANEL		
	ELECTRIC LINE (BY ELECTRICAL CONTRACTOR)		
	OVERHEAD ELECTRIC		

HR

Hurst-Rosche, Inc.
 SECRETARY OF STATE CONTROL NUMBER: 00092303
 1101 KERMIT DR, SUITE 620
 NASHVILLE, TN
 PH: 615.454.6615

www.hurst-rosche.com
 HILLSBORO, IL
 EAST ST. LOUIS, IL
 MARION, IL
 ARNOLD, MO
 SPRINGFIELD, IL

Peter James Murphy

SIGNATURE 06-18-2024
 DATE 03-31-2025
 LICENSE EXPIRES

MONTGOMERY BELL STATE PARK FOUR MILE CREEK
 CAMPGROUND RENOVATION
 1020 JACKSON HILL ROAD
 BURNS, DICKSON COUNTY, TENNESSEE
 SBC PROJECT NO. 126/054-01-2022

MARK	DATE	DESCRIPTION
1	6-5-2024	ADDENDUM #2
2	6-18-2024	ADDENDUM #3

DATE: 06-18-2024
 PROJECT NO: 530-0483
 DESIGN: JL DRAWN: JL CHECK: PJM

MONTGOMERY BELL STATE PARK
 PROPOSED SITE
 ELECTRICAL 2



Hurst-Rosche, Inc.
 SECRETARY OF STATE CONTROL NUMBER: 00092303
 1101 KERMIT DR, SUITE 620
 NASHVILLE, TN
 PH: 615.454.6615
 www.hurst-rosche.com
 HILLSBORO, IL
 EAST ST. LOUIS, IL
 MARION, IL
 ARNOLD, MO
 SPRINGFIELD, IL

Peter James Murphy
 SIGNATURE 06-18-2024
 DATE 03-31-2025
 LICENSE EXPIRES

MONTGOMERY BELL STATE PARK FOUR MILE CREEK
 CAMPGROUND RENOVATION
 1020 JACKSON HILL ROAD
 BURNS, DICKSON COUNTY, TENNESSEE
 SBC PROJECT NO. 126/054-01-2022

MARK	DATE	DESCRIPTION
1	6-5-2024	ADDENDUM #2
2	6-18-2024	ADDENDUM #3

DATE: 06-18-2024
 PROJECT NO: 530-0483
 DESIGN: JL DRAWN: JL CHECK: PJM

MONTGOMERY BELL
 STATE PARK
 PROPOSED SITE
 ELECTRICAL 3

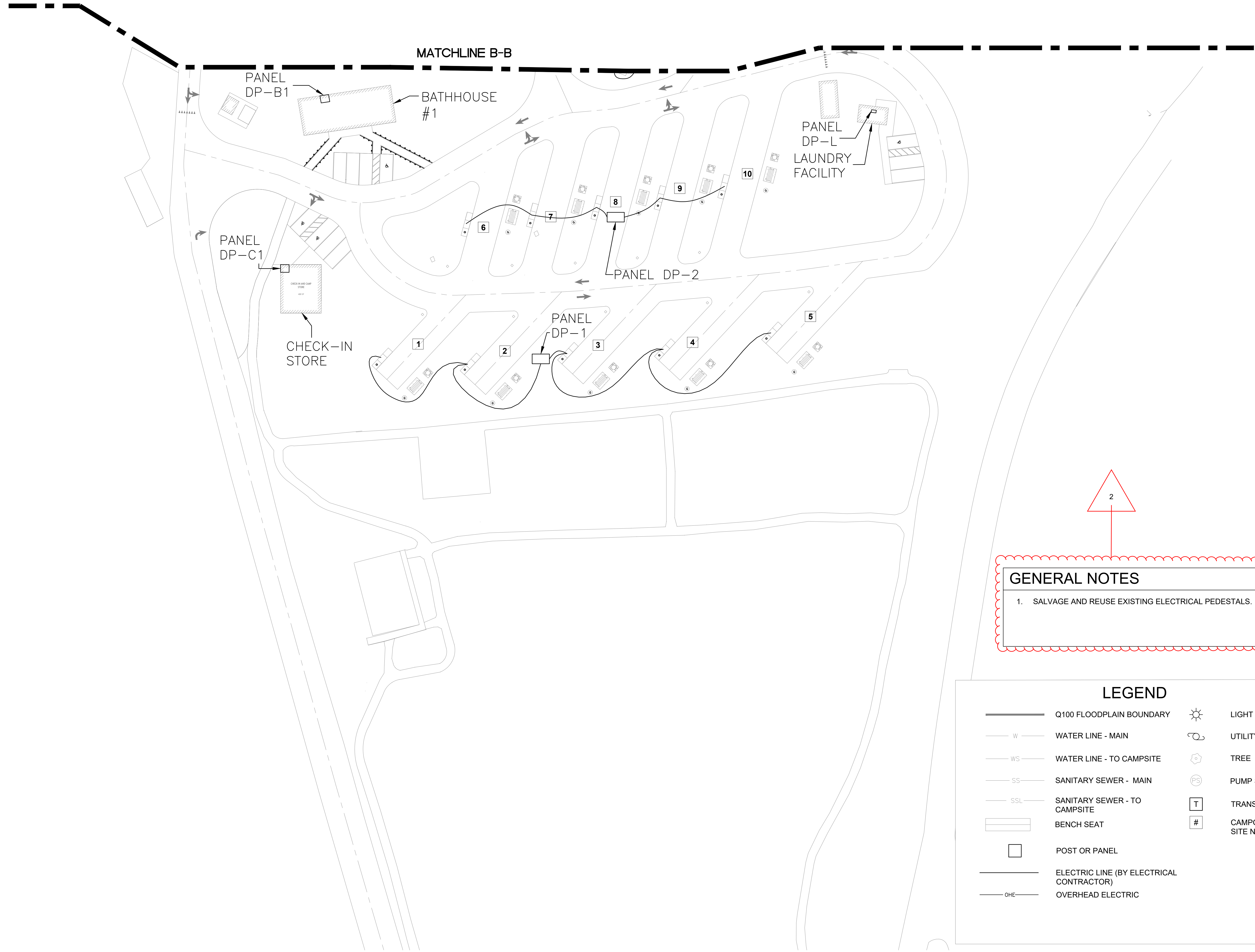

GENERAL NOTES

1. SALVAGE AND REUSE EXISTING ELECTRICAL PEDESTALS.

LEGEND

	Q100 FLOODPLAIN BOUNDARY		LIGHT POLE
	WATER LINE - MAIN		UTILITY POLE
	WATER LINE - TO CAMPSITE		TREE
	SANITARY SEWER - MAIN		PUMP STATION
	SANITARY SEWER - TO CAMPSITE		TRANSFORMER
	BENCH SEAT		CAMPGROUND SITE NUMBER
	POST OR PANEL		
	ELECTRIC LINE (BY ELECTRICAL CONTRACTOR)		
	OVERHEAD ELECTRIC		



Hurst-Rosche, Inc.
 SECRETARY OF STATE CONTROL NUMBER: 00002020
 1101 KERMIT DR. SUITE 620
 NASHVILLE, TN
 PH: 615.454.6615

www.hurst-rosche.com
 HILLSBORO, IL
 EAST ST. LOUIS, IL
 MARION, IL
 ARNOLD, MO
 SPRINGFIELD, IL



SIGNATURE: *Peter James Murphy*
 DATE: 06-18-2024
 LICENSE EXPIRES: 03-31-2025

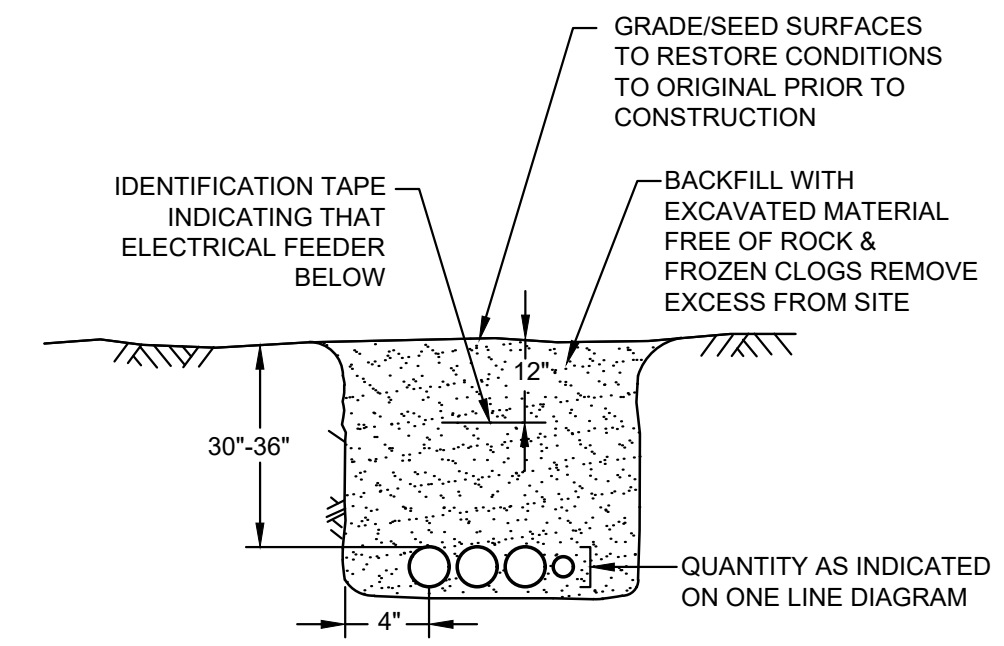

1 UTILITY TRENCH DETAIL
 E-501 SCALE: NONE

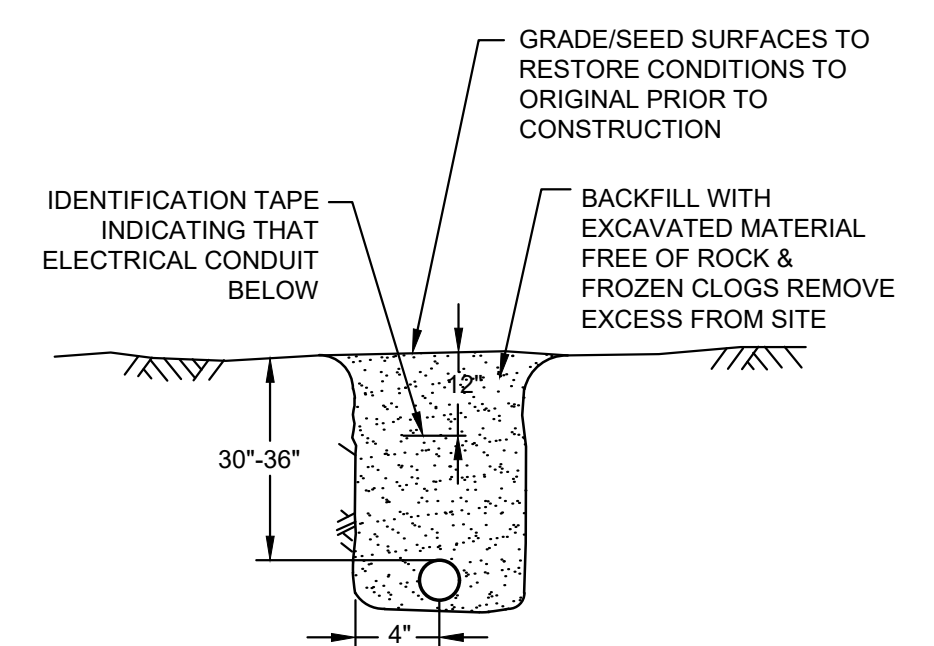

2 BURIED CONDUIT DETAIL
 E-501 SCALE: NONE

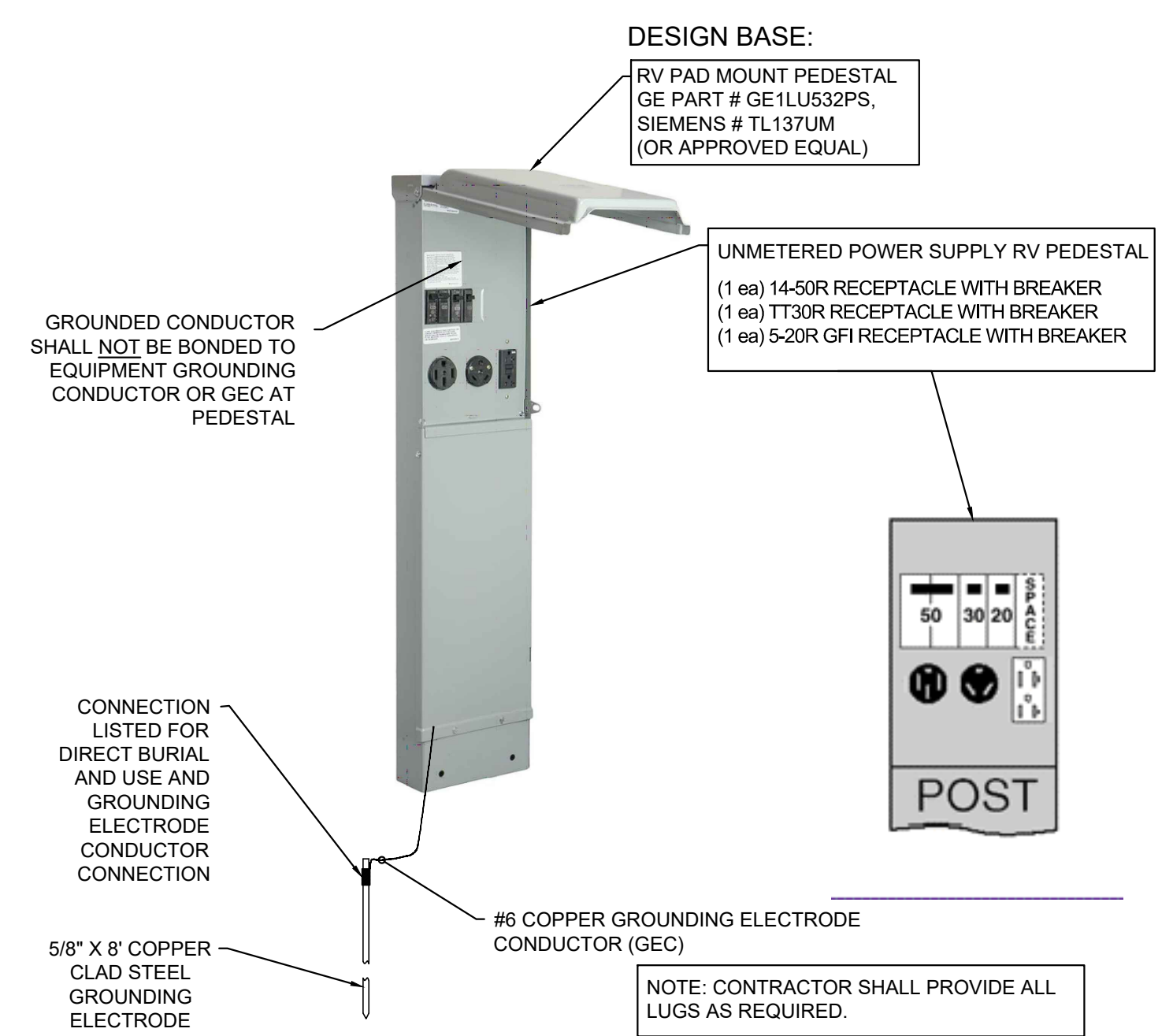

3 CAMPSITE SERVICE PEDESTAL WITH FEED-THRU LUGS
 E-501 SCALE: NONE

MONTGOMERY BELL STATE PARK FOUR MILE CREEK
 CAMPGROUND RENOVATION
 1020 JACKSON HILL ROAD
 BURNS, DICKSON COUNTY, TENNESSEE
 SBC PROJECT NO. 126/054-01-2022

MARK	DATE	DESCRIPTION
1	6-5-2024	ADDENDUM #2
2	6-18-2024	ADDENDUM #3

DATE: 06-18-2024
 PROJECT NO: 530-0483
 DESIGN: JL DRAWN: JL CHECK: PJM

DETAILS

E-501